



**WEDGETAIL**  
INDUSTRIES

# MPR308

MODULAR PUMP ACTION RIFLE

**OPERATOR'S MANUAL**





**This SAFETY & INSTRUCTION MANUAL should always accompany this firearm and be transferred with it upon change of ownership or when presented to another person.**

**A copy of this manual is available from [www.wedgetailindustries.com](http://www.wedgetailindustries.com)**

## INTRODUCTION

Thank you for purchasing a Wedgetail Industries™ MPR308 pump action rifle. Wedgetail Industries™ is proud to be the pre-eminent manufacturer of pump action rifles in Australia. When you purchase a Wedgetail Industries™ rifle you are helping to maintain Australian advanced manufacturing businesses and enhance the vital sovereign capability of manufacturing small arms in Australia.

Our goal for the MPR308 was to design, manufacture and support a modern pump action rifle. The MPR308 is based on the proven MSR architecture with modular upper and lower receiver sub-assemblies with proven ergonomics. The result is a rifle system that is highly reliable, accurate and durable.

The highest quality materials and finishes are used in the manufacture of the MPR308. When maintained correctly, the MPR308 will provide many years of reliable service. To support this goal, we maintain a complete supply of parts for the MPR308 in Australia, ready to dispatch. Please refer to the parts list and drawings and the back of this manual.

We hope you find the MPR308 to be a useful and reliable tool. Please feel free to contact us via email at [sales@wedgetailindustries.com](mailto:sales@wedgetailindustries.com) if you have any questions about the rifle or any of the information in this manual.



## CONTENTS





<b>1.0 ABOUT THIS MANUAL</b> .....	<b>4</b>	<b>6.0 MAINTENANCE</b> .....	<b>17</b>
1.1 WARNINGS AND SAFETY DATA	4	6.1 FIELD STRIPPING AND DISASSEMBLY	17
1.2 NOTES ON AMMUNITION	6	6.2 TO FIELD STRIP UPPER AND LOWER ASSEMBLY	18
<b>2.0 GENERAL DESCRIPTION OF THE MPR308</b> .....	<b>7</b>	6.3 TO FIELD STRIP THE BOLT CARRIER GROUP	20
2.1 MPR308 TECHNICAL DATA	7	6.4 TO REASSEMBLE THE BOLT CARRIER GROUP	21
<b>3.0 HOW THE MPR308 WORKS</b> .....	<b>8</b>	<b>7.0 CLEANING AND ENVIRONMENTAL CARE INSTRUCTIONS</b> .....	<b>22</b>
<b>4.0 HOW TO USE THE MPR308</b> .....	<b>9</b>	7.1 TO CLEAN THE UPPER RECEIVER GROUP AND BARREL	22
4.1 SAFETY	9	7.2 TO CLEAN THE LOWER RECEIVER	22
4.2 THE FIVE RULES OF FIREARM SAFETY	9	7.3 TO CLEAN THE BOLT AND CARRIER GROUP	22
4.3 WEARING OF CORRECT PPE	10	7.4 REASSEMBLY	22
4.4 THE OPERATING CONDITIONS OF THE MPR308	11	7.5 TEST AFTER REASSEMBLY	23
4.5 OPERATING CONTROLS	11	<b>8.0 ROUTINE OPERATOR MAINTENANCE</b> .....	<b>24</b>
4.6 CHANGING BETWEEN OPERATING CONDITIONS ON THE MPR308	14	<b>9.0 USING THE MPR308 IN EXTREME ENVIRONMENTS</b> .....	<b>25</b>
4.7 CLEARING THE RIFLE	14	9.1 TROPICAL OR WET CONDITIONS	25
4.8 MAGAZINE LOADED CONDITION	14	9.2 HEAVY RAIN	25
4.9 READY TO FIRE CONDITION	14	9.3 DRY, SANDY OR DUSTY CONDITIONS	25
4.10 TO APPLY 'SAFETY OFF'	15	9.4 SALTWATER IMMERSION AND SPRAY	25
4.11 TO GO TO 'UNLOADED' CONDITION	15	<b>10.0 TROUBLESHOOTING</b> .....	<b>26</b>
<b>5.0 FIRST FIRING OF THE MPR308</b> .....	<b>16</b>	<b>11.0 MPR308 MAINTENANCE SCHEDULE</b> .....	<b>27</b>
5.1 CLEANING BEFORE FIRING	16	<b>12.0 RIFLE NOMENCLATURE AND ASSEMBLY DRAWINGS</b> .....	<b>28</b>
5.2 LOADING THE MAGAZINE	16	<b>13.0 WARRANTY INFORMATION</b> .....	<b>42</b>
5.3 CLEARING STOPPAGES AND MALFUNCTIONS	17	<b>CONTACT INFORMATION</b> .....	<b>43</b>
		<b>OPERATORS NOTES</b> .....	<b>44</b>







## 1.0 ABOUT THIS MANUAL

The purpose of this manual is to provide information on the operation and safe use of the MPR308 rifle. The manual also provides instruction on user level maintenance of the rifle.

Make sure that you read this manual carefully and understand the information in it before to operating the rifle.

### 1.1 WARNINGS AND SAFETY DATA

	<b>WARNING!</b> NEVER ALLOW A FIREARM TO BE USED BY INDIVIDUALS WHO DO NOT UNDERSTAND ITS SAFE OPERATION.
	<b>WARNING!</b> SAFETY IS YOUR NUMBER ONE RESPONSIBILITY. THE FIRST CONCERN OF EVERY FIREARM OPERATOR SHOULD BE SAFETY. ENSURE YOU READ THE INSTRUCTIONS AND IF YOU FEEL UNCERTAIN ABOUT ANY OPERATIONAL ASPECTS OF YOUR FIREARM, PLEASE CONTACT WEDGETAIL INDUSTRIES™ AT SALES@WEDGETAILINDUSTRIES.COM
	<b>WARNING!</b> ALWAYS KEEP THE MUZZLE POINTED IN A SAFE DIRECTION WHEN LOADING, UNLOADING, CLEARING OR CHARGING THE RIFLE.
	<b>WARNING!</b> NEVER POINT A FIREARM ANYTHING YOU DO NOT INTEND TO SHOOT WHETHER OR NOT IT IS LOADED. ALWAYS TREAT EVERY FIREARM AS IF IT IS LOADED AND WILL FIRE.
	<b>WARNING!</b> IF THE FIREARM BECOMES IMMERSSED IN WATER, MAKE SURE YOU CLEAN AND DRY THE BARREL CAREFULLY BEFORE FIRING. NEVER FIRE THE RIFLE WITH WATER OR ANY OTHER OBSTRUCTION IN THE BORE.

	<b>WARNING!</b> THE BARREL WILL BECOME HOT ENOUGH TO CAUSE INJURY DURING FIRING. TAKE CARE TO AVOID TOUCHING THE BARREL. ALWAYS KEEP YOUR FIREARM POINTED IN A SAFE DIRECTION.
	<b>WARNING!</b> ALWAYS USE THE CORRECT AMMUNITION IN GOOD CONDITION FOR YOUR PARTICULAR FIREARM AS INDICATED BY THE MARKING ON THE FIREARM. NEVER USE NON-STANDARD, RELOADED, OR "HAND-LOADED" AMMUNITION.
	<b>WARNING!</b> BEWARE OF BARREL OBSTRUCTIONS. BE SURE THE BARREL IS CLEAR OF OBSTRUCTIONS BEFORE SHOOTING. MUD, WATER, SNOW OR OTHER OBJECTS MAY INADVERTENTLY LODGE IN THE BARREL BORE. A SMALL OBSTRUCTION CAN CAUSE A DANGEROUS INCREASE IN PRESSURE AND MAY DAMAGE YOUR FIREARM AND CAUSE INJURY TO YOURSELF AND OTHERS.
	<b>WARNING!</b> BE SURE ALL ACCESSORIES, SUCH AS GRIPS, SLINGS, SCOPES AND OTHER ACCESSORIES ARE COMPATIBLE WITH THE FIREARM AND THAT THE ACCESSORIES DO NOT INTERFERE WITH SAFE OPERATION. IT IS YOUR RESPONSIBILITY TO UNDERSTAND AND FOLLOW ALL OF THE INSTRUCTIONS IN THIS MANUAL, AS WELL AS THOSE WHICH MAY BE SUPPLIED WITH YOUR AMMUNITION AND ANY ACCESSORY.
	<b>WARNING!</b> NEVER DISASSEMBLE YOUR FIREARM BEYOND THE 'FIELD STRIPPING PROCEDURE' OUTLINED IN THIS MANUAL. IMPROPER DISASSEMBLY OR REASSEMBLY OF YOUR FIREARM MAY BE DANGEROUS AND CAN LEAD TO SERIOUS INJURY OR DEATH.
	<b>WARNING!</b> NEVER LOAD OR CYCLE LIVE AMMUNITION IN YOUR FIREARM ANYWHERE YOU WOULD NOT WANT TO FIRE THE FIREARM. LOADING LIVE AMMUNITION INTO A FIREARM IN A RESIDENTIAL AREA OR DWELLING IS EXTREMELY DANGEROUS. ONLY PRACTICE LOADING LIVE ROUNDS ON A FIRING RANGE OR OTHER SAFE PLACE TO FIRE A FIREARM. INSTEAD, USE INERT, 'DRILL ROUNDS' TO PRACTICE LOADING AND UNLOADING THE FIREARM.

## 1.2 NOTES ON AMMUNITION

A firearm and ammunition are a system and must work together. There are different types of ammunition for different types of firearms. Your firearm has been designed for ammunition of a specific type and a specific gauge or calibre. It is important to select the proper ammunition for your firearm.

Locate the cartridge designation marked on the firearm receiver. This information indicates the correct ammunition that must be used in your firearm. You are responsible for selecting ammunition that meets industry standards and is appropriate in type and calibre for this firearm.





Wedgetail Industries™ recommends the use of .308 Win ammunition from reputable manufacturers only.

Note: The MPR308 (.308 Win) was tested at the factory using ammunition from the following manufacturers:

- ▲ Australian Outback Ammunition .308 Win 168Gr Sierra HPBT 'MatchKing'.
- ▲ Australian Munitions F4.
- ▲ Federal .308 Win 175Gr 'Match King' Gold Medal.
- ▲ Federal American Eagle .308 Win 130 Grain JHP.

Note: Wedgetail Industries™ does not recommend the use of the following types of ammunition in the MPR308. Use of these types of ammunition may result in hard or tight extraction:

- ▲ PPU brand ammunition.
- ▲ Norinco brand ammunition.
- ▲ Steel case ammunition of any make.
- ▲ Military surplus ammunition of unknown quality or origin.
- ▲ Reloaded or hand-loaded ammunition.

	<b>WARNING:</b> NEVER USE AMMUNITION OF THE INCORRECT GAUGE OR CALIBRE. USING AMMUNITION OF THE INCORRECT GAUGE OR CALIBER MAY CAUSE DAMAGE TO YOUR FIREARM AND POSSIBLE SERIOUS INJURY TO YOU AND TO OTHERS.
	<b>WARNING:</b> NEVER USE CARTRIDGES OTHER THAN THOSE DESIGNATED BY THE MARKING ON THE FIREARM. DOING SO CAN RESULT IN DANGEROUSLY HIGH PRESSURES THAT MAY DAMAGE THE FIREARM AND POSSIBLY CAUSE SERIOUS INJURY TO YOURSELF AND OTHERS.
	<b>WARNING:</b> NEVER USE AMMUNITION NOT SPECIFICALLY DESIGNATED FOR USE IN YOUR FIREARM. FAILURE TO USE THE CORRECT TYPE OR CALIBER OF AMMUNITION MAY CAUSE THE FIREARM TO JAM, OR FAIL TO FIRE, OR MAY GENERATE EXCESSIVE PRESSURE WHICH CAN DAMAGE OR EVEN RUPTURE YOUR FIREARM, CAUSING PERSONAL INJURY OR DEATH TO THE SHOOTER OR BYSTANDERS.
	<b>WARNING:</b> DEATH, SERIOUS INJURY AND PROPERTY DAMAGE CAN RESULT FROM THE USE OF INCORRECT AMMUNITION OR BORE OBSTRUCTIONS. NEVER USE RELOADED AMMUNITION.

## 2.0 GENERAL DESCRIPTION OF THE MPR308

The MPR308 rifle series are designed and manufactured in Australia. The MPR308 rifle is a manually operated, helical bolt, magazine-fed rifle chambered in .308 Winchester.

The MPR308 rifles have the following characteristics:

- ▲ Spring assisted pump action
- ▲ Single stage AR pattern trigger
- ▲ Magpul AR15 grip
- ▲ A5 Extended length buffer tube
- ▲ Magpul AR15 butt stock
- ▲ WT25/AR10/SR25 type magazine
- ▲ Hand guard with M-LOK accessory slots
- ▲ Last round bolt hold open and bolt release

## 2.1 MPR308 TECHNICAL DATA

MPR308-02	
<b>Calibre</b>	.308 Winchester
<b>Weight (unloaded w/o accessories)</b>	3.55kg
<b>Length (stock collapsed)</b>	860mm
<b>Minimum Barrel Length</b>	408mm (16")
<b>Rifling</b>	6 Lands & Grooves, 1:10" RH Twist
<b>Magazine Capacity</b>	10 rounds
<b>Trigger Pull Weight</b>	6 lbs. (single stage trigger)
<b>Sustained rate of fire</b>	60 rounds per minute
<b>Range</b>	>700 meters

NOTE: Changes to the factory configuration of the MPR308 rifle by the end-user, including but not limited to, changes in barrel length, calibre, trigger mechanism, and recoil system may void the manufacturer's warranty.

It is your responsibility to comply with all state and federal firearm laws and regulations regarding the possession, transport, or modification of this product.

### 3.0 HOW THE MPR308 WORKS

To safely use the MPR308, you must understand how the MPR308 works. By understanding how all the parts function, you will be able to recognise malfunctions and fix them.

You will also be able to tell when a part is missing, worn, or damaged by examining the rifle.

The MPR308 requires you to manually move the bolt and carrier group rearwards against the return spring. The return spring is housed in the buffer tube. The butt stock is also mounted onto the buffer tube.

Starting from a live round in the chamber, the cycle of operation of the MPR308 is as follows:

1. **Firing:** When the trigger is squeezed, it rotates around the trigger pin and disengages from the notch on the hammer. The hammer is thrown forwards by the action of the hammer spring to strike the firing pin through the bolt.

The tip of the firing pin is forced through the central hole in the face of the bolt and strikes the round. This ignites the primer which in turn ignites the cartridge powder. The gas generated by the rapid burning of the cartridge powder forces the projectile through the barrel.

2. **Unlocking:** The rifle requires you to pull the pump action assembly rearwards to unlock the bolt from the barrel.

The pump shuttle is connected to the bolt carrier via the op rod. When the bolt carrier moves to the rear, the bolt cam pin follows the path of the cam track. This causes the bolt to rotate and unlock. When the bolt is fully unlocked, the bolt lugs line up with the slots in the barrel extension and the bolt moves rearwards.

- 3 **Extracting:** As the bolt and bolt carrier move to the rear,

the extractor, which is attached to the bolt head, withdraws the cartridge case from the chamber.

4. **Ejecting:** As the bolt moves rearward, the spent case clears the receiver and is forced out the ejection port opening by the spring-loaded ejector plunger.
5. **Cocking:** The continued rearward action of the bolt rides over the hammer forcing it to rotate downward into the lower receiver. The hammer catches on the disconnecter mounted to the trigger. When the trigger is released, the hammer is released from the disconnecter and catches on the trigger sear. This action re-cocks the rifle. The rearward movement of the bolt is arrested by the return spring and buffer.
6. **Feeding:** As soon as the bolt carrier has moved rearward and the recoil spring is fully compressed, the pump action assembly can drive forwards, either manually or with the assistance of the return spring. The magazine supplies another cartridge into position ready to be fed into the chamber.
7. **Chambering:** The compressed return spring in the buffer assembly forces the bolt towards the chamber. The lower two lugs of the bolt strike the base of the top round in the magazine and move it forwards and out of the magazine. As the bolt continues forward, the round is guided into the chamber by the feed ramp. When the round is fully chambered, the extractor overrides and grips the cannellure (groove at the base of the cartridge) of the round. The ejector plunger is depressed into the bolt face against the spring.

8. **Locking:** At the end of the forward movement of the bolt carrier, the bolt cam pin is forced by the bolt carrier cam track to rotate the bolt head and lock the bolt into the barrel extension. The rifle is then ready to fire again.

### 4.0 HOW TO USE THE MPR308

#### 4.1 SAFETY

You may be a new rifle owner or a seasoned professional, but it is vital that you maintain operational safety as your highest concern. When using any firearm, there is one critical safety point you must always keep in mind:

**ONLY CHAMBER A ROUND WHEN YOU INTEND TO FIRE!**

This may seem obvious, but you must be always aware of this simple rule. When you do not immediately want to fire another round, always remember to remove the last fired round from the chamber of the rifle by drawing the pump action assembly rearward and locking the bolt open and place the rifle on safe. Remember the rifle can fire without the magazine inserted if there is a live round left in the chamber.

To safely use the MPR308, the operator must be always aware of the following.

1. The rules of firearms safety including wearing correct PPE.
2. The operating condition of the MPR308:
  - whether there are rounds in the magazine,
  - whether there are rounds in the chamber,
  - the position of the manual safety catch.
3. How to use each control to change from one operating condition to another:
  - to load a magazine,
  - to chamber a round,
  - apply and disengage the safety catch,
  - fire the rifle,
  - unload a chambered round without firing the round,
  - remove the magazine.

#### 4.2 THE FIVE RULES OF FIREARM SAFETY

**The five rules of firearm safety are as follows and should be familiar to all firearm owners:**

1. **Treat every firearm as if it is loaded.** Any firearm handled by a person must be treated as if it is loaded and prepared to fire. Whether or not a firearm is loaded should not affect how a person handles the firearm in any instance.

**2. Never point the firearm at anything you do not want to shoot.** Firearm owners must be aware of the direction of their firearm's muzzle and what is in the path of the projectile if the firearm fires.

A person must ensure the path between the muzzle and target is clear of other people, equipment, buildings, or anything else that the person does not want to shoot.

**3. Keep the finger straight and off the trigger until ready to fire.**

A person must not place their finger on the trigger unless they intend to fire the rifle. You are the most important safety feature of any firearm.

The MPR308 has a strong and reliable mechanical safety, but a person must not rely solely on the mechanical safety for safe operation. You must always remember that any mechanical device can fail.

**4. Identify positive identification of the target and its surroundings.**

The disciplined shooter can positively identify the target and knows what is in front of and beyond the target.

You are responsible for all bullets that you fire from your rifle, including the bullet's destination.

**5. Know whether there is a cartridge in the chamber.** You must not forget the status of the rifle chamber. The rifle will fire without the magazine inserted, if there is a live round in the chamber of the rifle.

Whenever you have finished shooting, you must remove the magazine, manually open the bolt using the pump slide, and inspect the chamber to be sure that there are no rounds of ammunition in the chamber.

#### 4.3 WEARING OF CORRECT PPE

Other than the obvious hazard of live fire, using the MPR308 rifle exposes the user to the following hazards:

1. Combustion gasses. Only use the MPR308 in a well-ventilated area.
2. Lead contamination. Wash your hands thoroughly after firing and handling the MPR308.
3. Noise. The MPR308 is very loud when it fires. Always wear good quality, well fitted hearing protection when firing the MPR308.
4. Particles and gases escaping from the ejection port in the rare event of a ruptured case.

Always wear well fitted safety glasses rated for impacts when shooting the MPR308.

5. Hot surfaces. Parts of the MPR308, particularly the barrel, will get hot enough to cause serious burns if you touch those parts with bare skin. Always allow the parts of the MPR308 to cool before touching them.

#### 4.4 THE OPERATING CONDITIONS OF THE MPR308

The MPR308 has four main operating conditions:

1. Magazine containing rounds inserted into the rifle, no rounds in the chamber. (MAGAZINE LOADED).
2. Magazine containing rounds in the rifle, round in the chamber, safety on. (READY TO FIRE).
3. Magazine loaded, round in the chamber, safety off. (SAFETY OFF).
4. No magazine loaded, no round in the chamber. (UNLOADED)

To use the MPR308 safely and effectively, it is essential that you can:

1. Identify which condition the MPR308 is in.
2. Know how to go from one condition to any other condition using the operating controls.

You should practice using all the operating controls of the rifle with no ammunition present, so you understand what the controls do and how to use them to put the MPR308 in any one of the four operating conditions. The operating controls are described below. Refer to the drawings.

#### 4.5 OPERATING CONTROLS

The main operating controls of the MPR308 are the safety selector, the charging handle and the bolt release. All three controls can be used by left and right-handed shooters. Familiarise yourself with the operating controls below and practice using them without any ammunition present.

##### SAFETY SELECTOR

The safety selector is located on the lefthand side of the lower receiver above the pistol grip.

When the safety selector is set to **SAFE**, the trigger lever is locked, shown below.

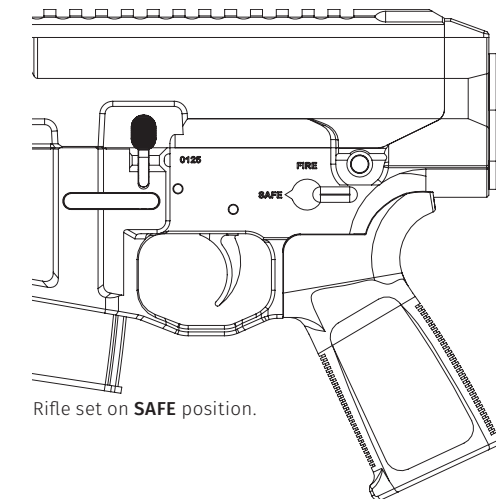

Rifle set on **SAFE** position.

When the safety selector is set to **FIRE**, the rifle will fire when the trigger is pulled, shown below.

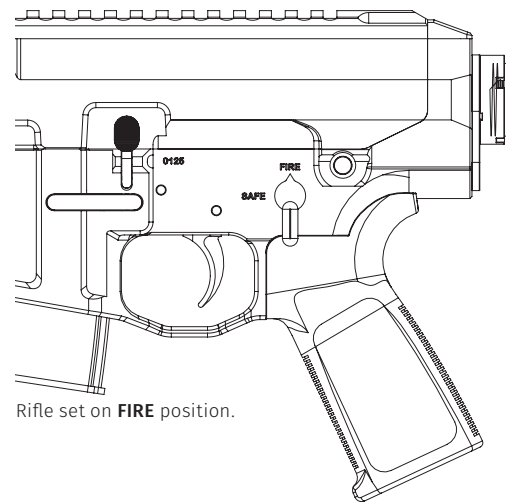

Rifle set on **FIRE** position.

**NOTE:** The rifle can only be set to **SAFE**, when the hammer is cocked, that is, when the bolt has been drawn back and let go.

#### COCKING THE WEAPON WITH THE PUMP ACTION ASSEMBLY

The pump action assembly is used to draw the bolt rearward. The pump action assembly has grip panels on both sides and a 1913 rail underneath. The pump action assembly should be pulled straight back and all the way to the rear.

The pump action assembly will remain in the rearward position after the bolt group is locked rearward.

The pump action assembly does not move when the rifle is fired.

The bolt carrier group only moves with the pump action assembly.

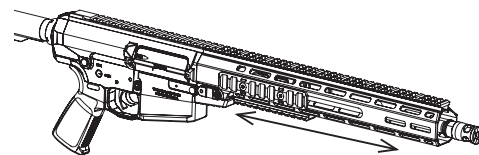

The pump action assembly moves to cycle the action.

#### BOLT CATCH LEVER

The bolt catch lever is used to keep the bolt carrier group (BCG) held to the rear. It can be applied manually to keep the BCG rearward. The bolt catch also activates automatically when the magazine is empty. It will stay activated when the empty magazine is removed. The bolt catch can be depressed to release the BCG and chamber a new round from the magazine.

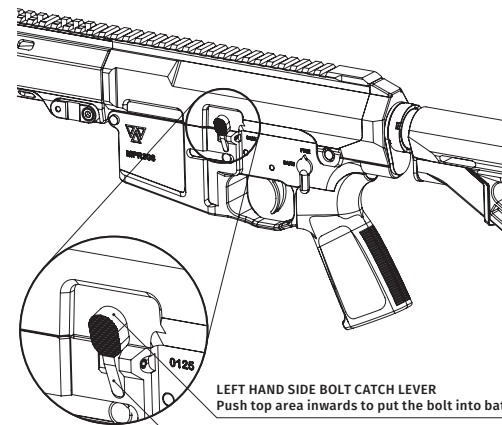

The main function of the buffer spring is to assist in the fore-end staying in the forward position. When using the MPR308, it is recommended to drive the pump forward using the supporting hand, rather than relying on the spring to strip rounds from the magazine.

#### MAGAZINE RELEASE BUTTON

The magazine catch holds the magazine into the rifle. The magazine catch is automatically applied when a magazine is inserted into the magazine well. The magazine catch is released by depressing the button on the righthand side of the rifle.

To release the magazine from the rifle:

1. Depress the magazine release button.
2. The magazine will fall out of the magazine well. If you want to retain the magazine, hold onto the magazine before you push the magazine release button.

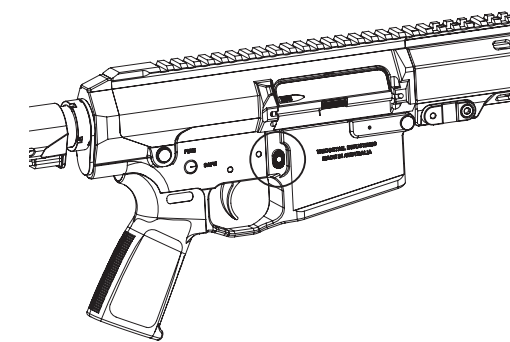



#### 4.6 CHANGING BETWEEN OPERATING CONDITIONS ON THE MPR308

Once you have familiarised yourself with the controls and operation of the MPR308, you are ready to practice putting the MPR308 into different operating conditions (Magazine Loaded, Round in the Chamber, Ready to Fire, Unloaded).

Never cycle live ammunition through the rifle anywhere except at a firing range or another safe place to fire the MPR308 rifle. Never cycle live ammunition in a residential area, dwelling, or any other area where you would not want to fire a firearm. If you want to practice loading cartridges with the MPR308, purchase inert, non-firing 'drill rounds' for this purpose.

#### 4.7 CLEARING THE RIFLE

The most important step whenever you handle a firearm is to check to make sure the firearm does not contain any ammunition in either the chamber or the magazine. To clear the MPR308, use the following procedure:

1. Keeping the rifle pointed in a safe direction and with your finger clear of the trigger, hold the rifle by the pistol grip using your master hand.
2. Observe the safety catch. If the safety catch is on 'FIRE', rotate the safety catch counterclockwise so it is pointing at 'SAFE'. The firing catch will only go to safe if the rifle hammer is cocked. If the firing catch will not go to safe, the rifle hammer is not cocked.
3. If the magazine is fitted, remove the magazine by pushing the magazine release button.
4. Use the pump action assembly to draw the bolt carrier group all the way to the rear.
5. With the bolt held back, apply the bolt catch.
6. Inspect the chamber for ammunition. If there is no

ammunition in the chamber, it is safe to proceed with handling the rifle.

#### 4.8 MAGAZINE LOADED CONDITION

The 'Magazine Loaded' Condition is when there is a magazine in the rifle but no round in the chamber.

Using an empty magazine and with no ammunition present, practice putting the rifle into the

'Magazine Loaded' condition:

1. Hold the rifle's pistol grip with your master hand.
2. With your non-master hand, draw the pump action assembly to the rear as far as it will go.
3. While keeping the pump action assembly held back, apply the bolt catch from either the lefthand side or right-hand side of the rifle.
4. Slowly release the pump action assembly until the bolt group is held in the rear position by the bolt catch.
5. Put the safety catch to 'SAFE'.
6. Insert an **EMPTY** magazine into the magazine well with your non-master hand. You will hear a click as the magazine catch engages on the magazine. Pull downward on the magazine to make sure it is seated.

#### 4.9 READY TO FIRE CONDITION

The rifle is now ready to go to 'Ready to Fire'. To go to 'Ready to Fire' condition:

1. Ensure that, for this practice, there are no rounds in the magazine by looking into the magazine well.
2. From either the left-hand side or the right-hand side,

release the bolt catch. The bolt group will move forward very quickly under spring pressure.

3. The safety catch should still be on 'SAFE'.

The rifle is now in 'Ready to fire' condition and can go to 'Safety off' condition.

#### 4.10 TO APPLY 'SAFETY OFF'

1. Rotate the safety catch to 'FIRE'.
2. Squeeze the trigger. You will hear the hammer drop, indicating that a round would have been fired.

#### 4.11 TO GO TO 'UNLOADED' CONDITION

1. Check the safety to be sure it is set on 'SAFE'.
2. Remove the magazine from the rifle.
3. With your non-master hand, draw the pump action assembly to the rear as far as it will go.
4. The live round will be ejected from the chamber. Retain the live round.
5. While keeping the pump action assembly, apply the bolt catch.
6. Slowly release the pump action assembly until the bolt group is held in the rear position by the bolt catch.
7. Inspect the chamber to ensure there is no round in the chamber.
8. If there is no round in the chamber, release the bolt forward using the bolt catch.
9. Apply the safety selector to 'FIRE'.

10. Pull the trigger to release the hammer forwards. The Safety selector will not go to 'SAFE' as the hammer is not cocked.

11. The rifle is now in the **UNLOADED** condition.

#### PRE-FIRING INSPECTION, CLEANING, AND MAINTENANCE

Now that you are familiar with the operating controls and operating conditions of the MPR308 rifle.

You can also sight in your rifle and practice firing the rifle.

As you should always do when picking up a rifle, first clear the rifle following the procedure in this manual. This ensures the rifle is in the **UNLOADED** condition.

## 5.0 FIRST FIRING OF THE MPR308

### 5.1 CLEANING BEFORE FIRING

Once the rifle is unloaded, check to make sure the working parts are properly lubricated. Refer to the section – Care and Maintenance. It is important to make sure the working parts are properly lubricated. Using a rifle that is not properly lubricated will cause malfunctions and excessive wear on the rifle's working parts.

It is also very important to check the barrel for obstructions and pull the barrel through with a clean swab or mop to remove excess oil. When the rifle was shipped, the bore was given a coat of protective oil. Firing the rifle without removing this oil will cause higher than normal pressures in the bore of the weapon as the bullet tries to force past the oil layer.

To remove the oil from the bore:

1. Lock the bolt of the rifle back.
2. Apply a clean patch to the flexible cleaning pull-through.

Now that the rifle is ready to be fired, you can practice loading the magazine.

### 5.2 LOADING THE MAGAZINE

To load cartridges into the magazine, follow the procedure below.

1. Hold the magazine firmly in the non-master hand, resting the base of the magazine on a flat surface.
2. Note the front and rear of the magazine. The magazine has an engraving of a cartridge marked 7.62x51 on each side of the magazine, below the feed lips. This indicates which way round the cartridges face.
3. Pick up a cartridge with the master hand. Check that the

cartridge is the correct type and is not excessively dirty, corroded, deformed or otherwise in poor condition.

4. With the cartridge facing bullet forwards, align the cartridge with the back wall of the magazine.

Press the cartridge downward into the magazine, between the feed lips. The cartridge will snap into position.

5. Make sure the cartridge is pushed up against the rear wall of the magazine.
6. To fully load the magazine, repeat the above until the magazine is full. The magazine should hold 10 cartridges. When the last round is loaded, it should still be possible to press the last round downward approximately 5mm further into the magazine.



### 5.3 CLEARING STOPPAGES AND MALFUNCTIONS

**The most common malfunction will be either a mis-fed round or an empty case stuck in the receiver. To clear either of these malfunctions, carry out the following:**

1. Use the pump action assembly to bring the bolt all the way to the rear.
2. Apply the bolt catch to keep the bolt to the rear.
3. Remove the magazine.
4. Remove the live round or fired case.
5. Re-insert the magazine.
6. Release the bolt catch to send the bolt forward and chamber a new round.
7. Carry on firing.



**WARNING:** AMMUNITION THAT HAS BEEN INVOLVED IN A STOPPAGE MUST BE REMOVED FROM USE AND MUST NEVER BE REPLACED IN THE MAGAZINE. AMMUNITION MUST NOT BE USED AS A TOOL DURING STOPPAGES. THESE RULES APPLY WHETHER THE AMMUNITION APPEARS TO BE DAMAGED OR NOT.

## 6.0 MAINTENANCE

Other than disassembly as described for cleaning, any maintenance should only be carried out by the Wedgetail Industries™ approved armourer or by a suitably qualified gunsmith.

### 6.1 FIELD STRIPPING AND DISASSEMBLY

Prior to any disassembly, ensure your rifle is at the 'UNLOAD' condition by carrying out the unloading and rifle clearing steps as described earlier in this manual. Follow the sequence of steps as listed below to 'Field Strip' your rifle.

Do not strip your rifle down any further than specified in these instructions. Detailed stripping of the subassemblies should only be conducted at the Wedgetail Industries™ factory or by a suitably trained and accredited gunsmith. Ensure you conduct any disassembly work in a clean area when at home or on a clean mat in the field. Make sure the area is clear of tools, parts, or other objects that might damage the finish on the rifle.

## 6.2 TO FIELD STRIP UPPER AND LOWER ASSEMBLY

1. Set the safety selector lever to 'SAFE' position.

The selector lever will only rotate with the hammer cocked.

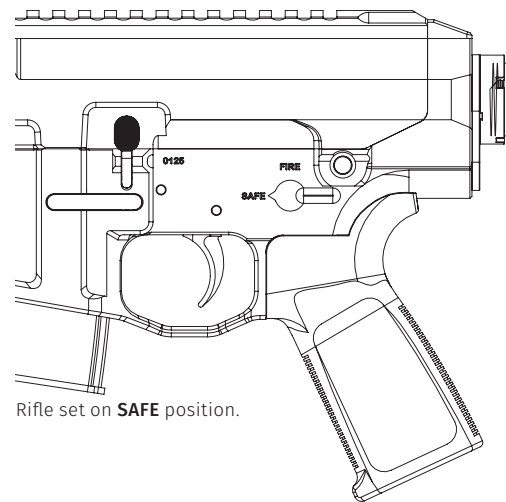

Rifle set on **SAFE** position.

2. To open the receivers, push the rear takedown inwards, from left to right. If the pin is tight, use a soft, non-marking drift or wooden dowel and a soft faced hammer to get it started.

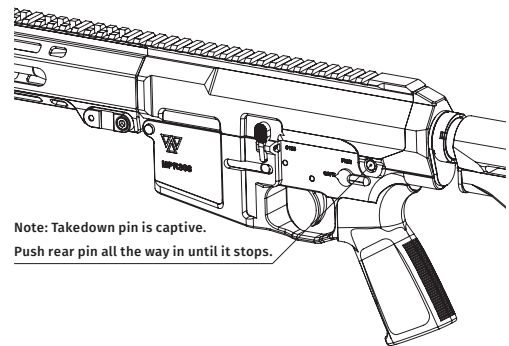

Note: Takedown pin is captive.  
Push rear pin all the way in until it stops.

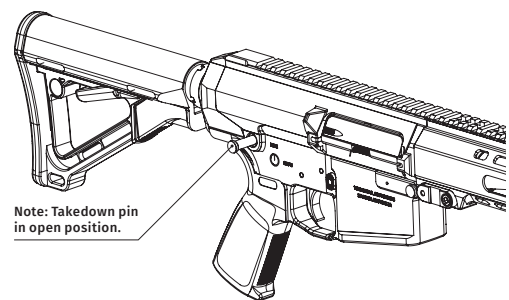

Note: Takedown pin in open position.

3. The upper and lower receiver assemblies will then rotate apart around the front pivot pin.  
Disengage the front take pivot pin by pushing it from left to right. The upper and lower receivers can now be separated.
4. Pull back on the pump action assembly to move the carrier to the rearward position to expose the rear of the bolt carrier group.

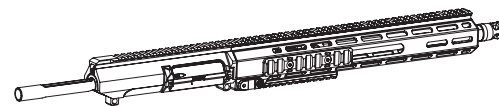

5. Rotate the latch counterclockwise to remove the bolt carrier group from the upper receiver.

Note: Latch is captive and rotates between detent positions.  
Latch shown in locked position.  
Rotate it anticlockwise to the open position.

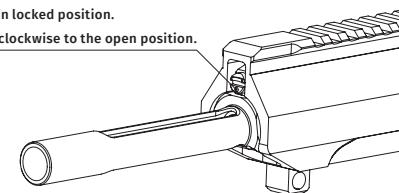

Note: Latch shown in open position.  
The bolt carrier can now be removed from the upper receiver.

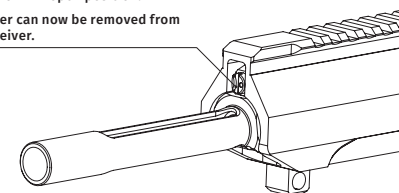

6. To remove the handguard, remove the socket capped cross bolts using a 4mm Allen key and slide the handguard forwards over the barrel.

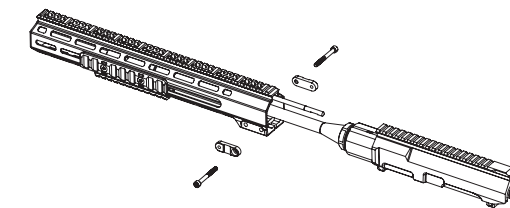

7. Note the buffer and buffer spring are not required to be removed in regular maintenance.

Do not unscrew the castle nut or unscrew the buffer tube from the lower receiver.

### 6.3 TO FIELD STRIP THE BOLT CARRIER GROUP

1. Remove the firing pin retaining pin from the bolt carrier by pushing it out from right to left.
2. Tilt the bolt carrier so the firing pin falls out of the rear of the bolt carrier.
3. Push the bolt in so the cam pin rotates to the rear.
4. Pull the cam pin out of the bolt.
5. Remove the bolt assembly by pulling it forward and out of the bolt carrier.

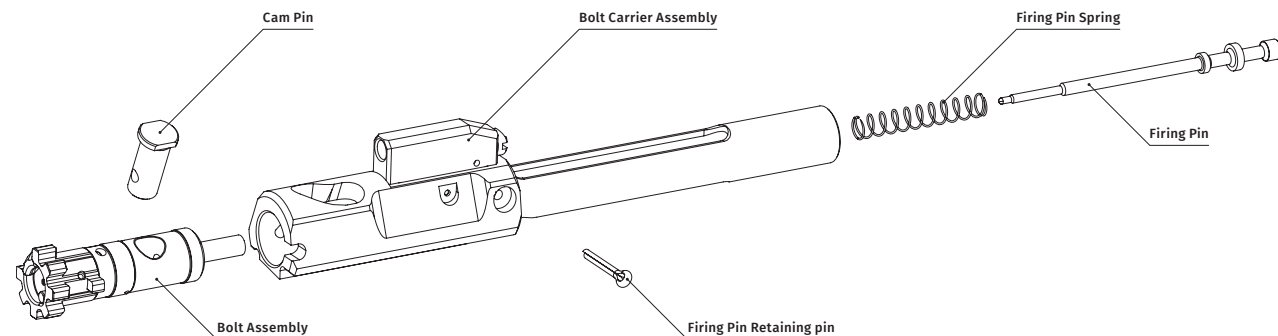

**WARNING:** DO NOT ATTEMPT TO STRIP THE BOLT OR BOLT CARRIER DOWN ANY FURTHER THAN AS DESCRIBED ABOVE. DAMAGE OR LOSS OF PARTS MAY OCCUR. DETAILED STRIPING OF THE SUBASSEMBLIES SHOULD ONLY BE CONDUCTED BY WEDGETAIL INDUSTRIES™ OR BY A SUITABLY TRAINED AND ACCREDITED GUNSMITH.

### 6.4 TO REASSEMBLE THE BOLT CARRIER GROUP

1. Push the bolt into the bolt carrier. Note that the cam pin hole in the bolt does not go all the way through the bolt. This means the cam pin can only be inserted into the bolt from one side. This feature prevents the bolt from being incorrectly re-assembled.
2. Line up the bolt cam pin hole with the bolt carrier cam pin track, at the rear of the cam pin track.
3. Insert the cam pin through the cam pin track in the bolt carrier and into the cam pin hole in the bolt. Make sure the firing pin hole in the cam pin is in line with the bolt carrier – that is, so the firing pin can go through the firing pin hole in the cam pin.
4. Pull the bolt forward so that the cam pin rotates and is in the fully forward position.
5. Hold the bolt carrier vertically so the bolt is facing down. Drop the firing pin and spring into the bolt so that it goes all the way into the bolt as far as it can.
6. Push the firing pin forwards and compress the spring. Now insert the firing pin retaining pin all the way into the bolt carrier.

7. Move the bolt in and out of the carrier to ensure it moves freely.
8. Push the bolt all the way into the carrier. Make sure the tip of the firing pin protrudes slightly from the bolt face when you press on the firing pin. If it does not, remove the firing pin and reinstall.
9. Pull the bolt all the way forward so the cam pin is as far forward as it will go.
10. The bolt carrier is now ready to insert into the rifle.

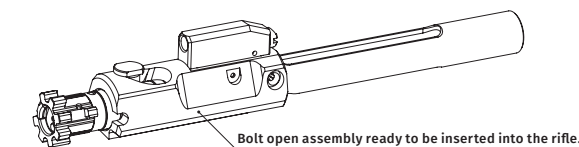

## 7.0 CLEANING AND ENVIRONMENTAL CARE INSTRUCTIONS

### 7.1 TO CLEAN THE UPPER RECEIVER GROUP AND BARREL

The barrel is to be cleaned as follows:

1. Exterior: The exterior of the barrel can be cleaned using a double ended bristle brush and lightly oiled by wiping over with a lightly oiled piece of flannelette cloth. Clean the exterior of the barrel, paying particular attention to the grooves in the flash hider and the rail interface system.  
**CAUTION** Do not use wire brushes on aluminium surfaces.
2. Interior: Clean using a cloth or flannelette ensuring that the pump mechanism track is clean and the internal area is free of dirt or debris.
3. Chamber. The chamber is cleaned using the chamber brush attached to the cleaning rod and wiped dry using a piece of flannelette; and
4. Bore. To clean the bore: Any fouling of the bore can be removed by using the wire bore brush dipped in CLP (or similar). To do this, attach the bore brush to the assembled length of cleaning rod (minus handle), drop the rod through the barrel from the chamber end, then attach the cleaning rod handle (if required) and pull through in a smooth motion.
5. Once this is completed, repeat using flannelette or a mop brush attachment.

### 7.2 TO CLEAN THE LOWER RECEIVER

Clean the lower receiver group as follows:

1. Clean the external surfaces using flannelette or cloth and a bristle brush.
2. Clean the trigger mechanism and all internal components with flannelette and/or cotton que tips, ensuring that it is free of dirt and debris; and dry and lightly oil – do not oil polymer surfaces.

### 7.3 TO CLEAN THE BOLT AND CARRIER GROUP

**Bolt Group.** The bolt group is to be cleaned as follows:

1. Wipe all oil residue from inside the bolt carrier (use a rod section and flannelette), bolt key, bolt and firing pin. The bolt face is to be left clean and free from oil. Use a bristle brush to clean the bolt face and locking lugs.
2. The body of the bolt carrier can be wiped over with a lightly oiled piece of flannelette.
3. Assemble the bolt group.
4. To lubricate the bolt carrier, press the bolt head in and apply one drop of oil to the front of the cam and one drop to the rear of the cam.
5. Dry and lightly oil all surfaces.

### 7.4 REASSEMBLY

Reassemble you rifle in reverse order to the described disassembly procedure.

### 7.5 TEST AFTER REASSEMBLY

Once the rifle has been reassembled, it is important to check that it functions correctly and that all parts function as they should. The following procedure is to be used to test a rifle after assembly:

1. Checking Safety: Pull the pump action assembly to the rear and release it, set the safety selector lever on **'SAFE'**.
2. Squeeze the trigger and you should hear no sound, as the hammer should not fall.
3. Release the trigger and then set the safety selector lever to **'FIRE'**.
4. Squeeze and keep the trigger depressed. A loud click should be heard as the hammer falls.
5. Pull the pump action assembly to the rear and release it while keeping the trigger depressed.  
  
The hammer should not fall but be held by the disconnecter.
6. Release the trigger. A dull click should be heard as the hammer is released from the disconnecter and drops part way to engage with the trigger sear; and
7. Pull the trigger to fire the action. After the trigger is pulled and the hammer drops, the safety selector lever should not be able to move to the **'SAFE'** position.

## 8.0 ROUTINE OPERATOR MAINTENANCE

Perform routine maintenance after each firing session or once daily while operating in normal field conditions. Ensure rifle is clear prior to performing any maintenance. When cleaning the bore always pass the cleaning rod through the chamber end towards the muzzle.

1. Fieldstrip the rifle as detailed in this manual.
2. Clean bore by patching first with a patch saturated in Simple Green, SLIP 2000 Carbon Killer or approved solvent. Patch bore with bore brush several times. Punch with a dry patch to remove carbon residue and cleaning solvent.

**NOTE:** If you see degradation in accuracy clean bore using a copper solvent per solvent manufacturer's instructions.

Check for cleanliness by punching with a clean patch. If the patch does not come out clean, repeat steps 2 until it does.

3. Wipe Bolt Carrier, interior of Upper Receiver, with a cloth (slightly dampened with cleaning solvent if available).
4. Scrub the face of the bolt with a GP brush dipped in cleaning solvent or CLP. Thoroughly wipe away any remaining cleaning solvent or CLP with a rag.

5. Apply a light coat of lubricant to all contact surfaces as shown below:

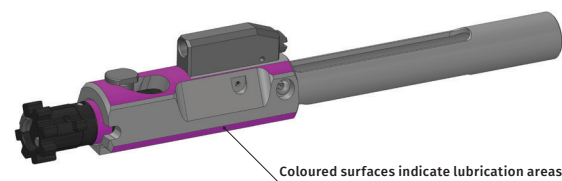

Additional lubrication points are as follows:

- Lightly lube the cam pin and the cam track.
- Upper receiver bore.
- Hammer contact points with bolt carrier and sear.
- Hammer and trigger pivot pins.

## 9.0 USING THE MPR308 IN EXTREME ENVIRONMENTS

### 9.1 TROPICAL OR WET CONDITIONS

In tropical or wet conditions inspect and carry out normal daily cleaning on a more frequent basis.

Extra applications of oil may be required on the external steel components. The safety catch should be manipulated and oiled daily to prevent sticking.

### 9.2 HEAVY RAIN

In heavy rain, inspect and carry out normal daily cleaning on a more frequent basis. If water is allowed to accumulate in the bore of the rifle, a bulged barrel or breech explosion may occur when firing. To prevent this, carry the rifle with the muzzle facing down.

### 9.3 DRY, SANDY OR DUSTY CONDITIONS

During dry, sandy or dusty conditions clean as for normal daily cleaning but keep the exterior of the rifle oil free. A light coating of graphite powder can be used as a lubricant on the working parts and trigger mechanism in extreme conditions.

### 9.4 SALTWATER IMMERSION AND SPRAY

If the rifle is affected by saltwater immersion or spray, the muzzle is to be pointed down and the rifle cocked (this will ensure all water is cleared from the barrel and there is no chance of a hydro-static lock).

As soon as practicable when ashore, strip the rifle and wash thoroughly in fresh water, then dry. Carry out normal daily cleaning and additional cleaning. Additional applications of oil may be required on external components to prevent rust. If continual exposure to salt water is experienced, a light coating of grease may be required on the external components.

## 10.0 TROUBLESHOOTING

MALFUNCTION	TEST OR INSPECTION	CORRECTIVE ACTION
Double feed	Dirty magazine	Clean magazine
Round will not chamber	Dirty or corroded ammunition	Clean or replace ammunition
	Damaged ammunition	Replace ammunition
	Carbon in chamber	Clean chamber
Bolt will not close	Dirt, corrosion, or carbon in barrel or bolt locking lugs	Clean bolt locking lugs
Bolt will not extract round	Frozen extractor	Remove bolt and clean extractor
	Restricted buffer assembly	Clean buffer and spring
	Restricted movement of bolt carrier group	Remove, clean, and lubricate bolt
	Dirty chamber	Clean chamber
	Cartridge stuck	Push cartridge out with cleaning rod
Selector lever binds	Dirty selector lever	Check, clean and lubricate
Bolt carrier hung up	Round caught between the bolt and the upper receiver	Remove magazine, remove loose ammunition
Bolt fails to lock after last round fired	Faulty magazine	Replace the magazine

## 11.0 MPR308 MAINTENANCE SCHEDULE

PART	ROUND COUNT										
	1-1,000	100 – 500	500 – 1,000	1,000 – 2,000	2,000 – 3,000	3,000 – 4,000	4,000 – 5,000	5,000 – 6,000	6,000 – 7,000	7,000 – 8,000	10,000
<b>Barrel Assembly</b>	Bore should be cleaned every 800-1,000 rounds.										Replace@20K
<b>Buffer Spring Assembly</b>	Return to Wedgetail Industries™ for replacement.										Replace@20K
<b>Bolt</b>	Inspect for cracks/missing lugs.										Replace@20K
<b>Ejector</b>	Test for free movement.										Replace
<b>Ejector Springs</b>	Compare free length to a new spring.										Replace
<b>Extractor</b>	Inspect for wear to ejector face.										Replace
<b>Extractor Springs</b>	Compare free length to a new spring.										Replace
<b>Firing Pin</b>	Inspect tip for deformation.										Replace
<b>Firing Pin retaining pin</b>	Verify retainer will remain in the carrier.										Replace
<b>Cam Pin</b>	Inspect for heavy wear and cracks.										Replace
<b>Hammer Trigger Pins</b>	Inspect for wear and cracks.										Replace
<b>Disconnecter Spring</b>	Verify spring pushes disconnecter into resting position and disconnecter is free moving.										Replace
<b>Selector Detent</b>	Inspect for worn firing pin tip.										Replace
<b>Bolt Catch Assembly</b>	Inspect for wear, cracks and warpage to catch. Verify free movement in Lower receiver.										Replace
<b>Magazine Catch Spring</b>	Compare free length to a new spring.										Replace
<b>Hammer Spring</b>	Check primer indent for spring tension. Compare to new spring.										Replace
<b>Trigger Spring</b>	Verify trigger reset. Compare to a new spring.										Replace

**12.0 RIFLE NOMENCLATURE AND ASSEMBLY DRAWINGS**  
**MPR308 SUB-ASSEMBLIES**

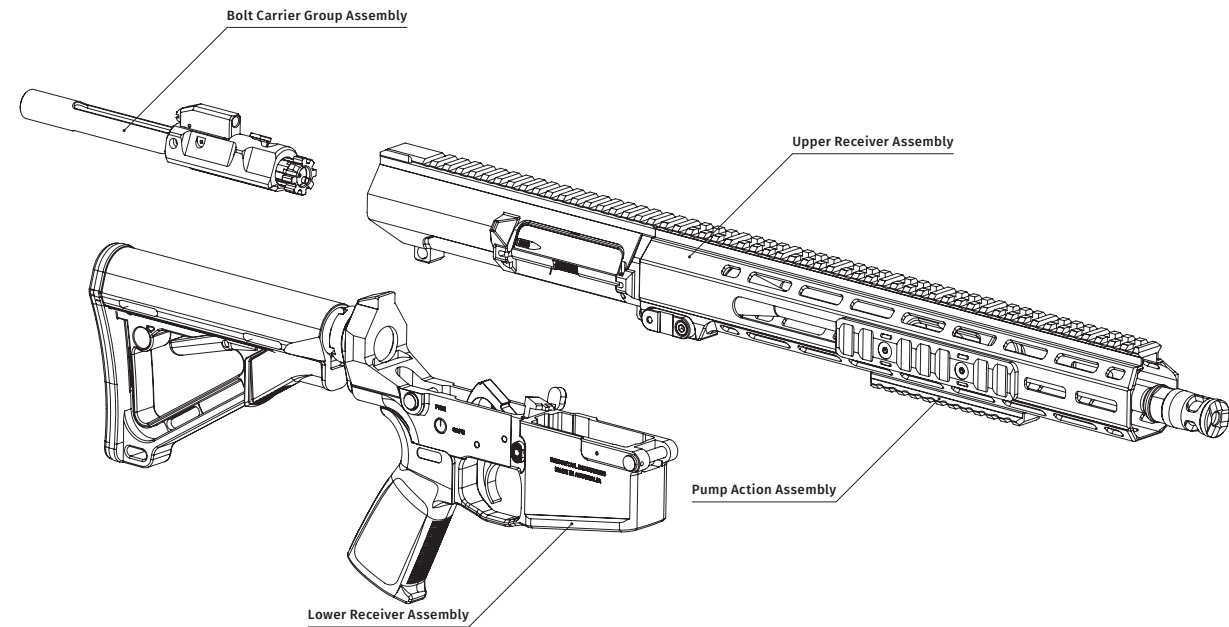

**MPR308 COMPONENT NOMENCLATURE**

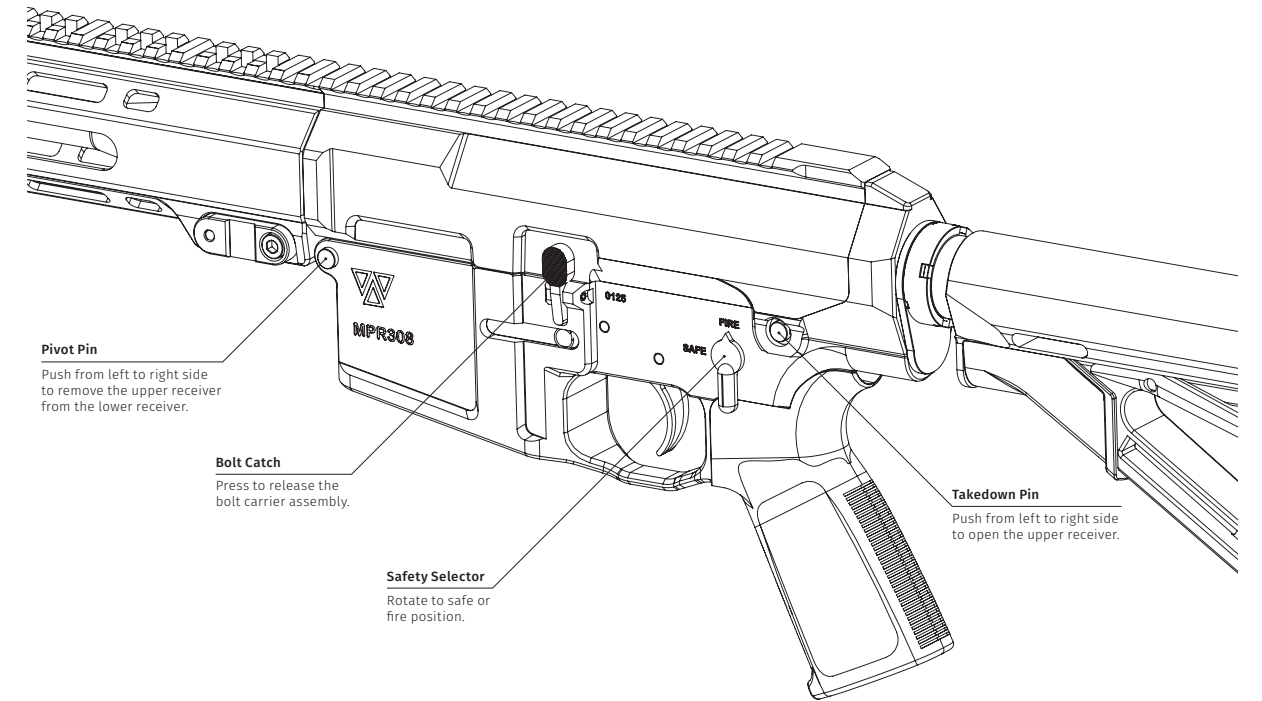



**BOLT CARRIER GROUP SUB ASSEMBLY**

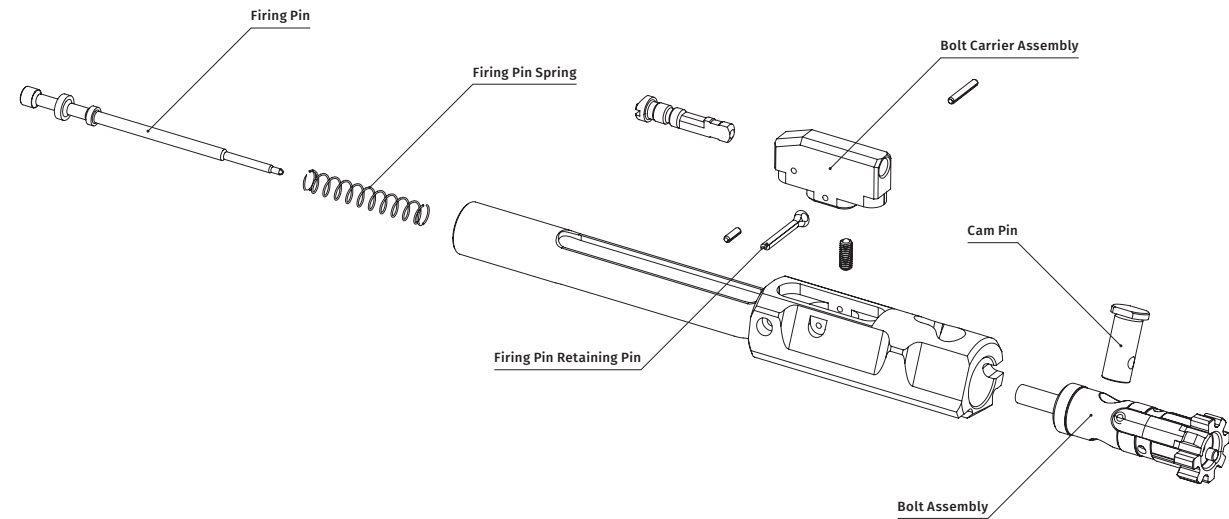

**UPPER AND LOWER RECEIVER ASSEMBLY**

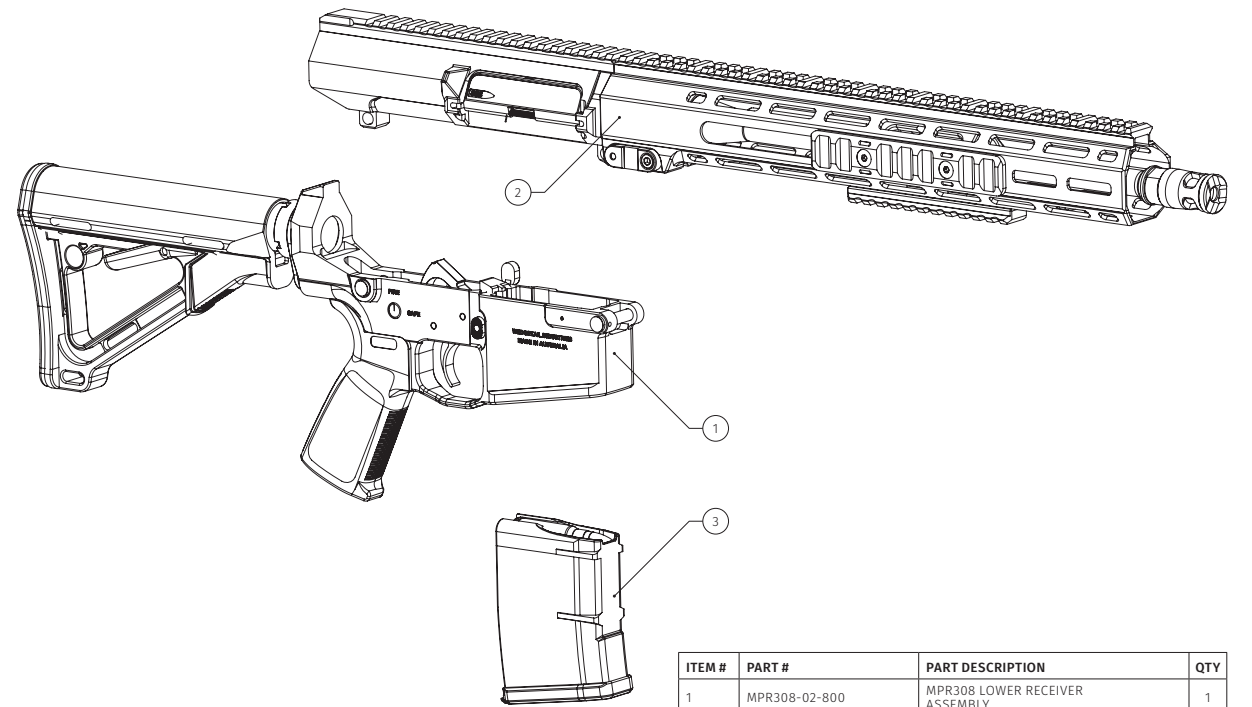

ITEM #	PART #	PART DESCRIPTION	QTY
1	MPR308-02-800	MPR308 LOWER RECEIVER ASSEMBLY	1
2	MPR308-02-809	MPR308 COMPLETE UPPER RECEIVER ASSEMBLY	1
3	MPR308-00-8002	MAGAZINE 10RD	1

LOWER RECEIVER ASSEMBLY- EXPLODED VIEW

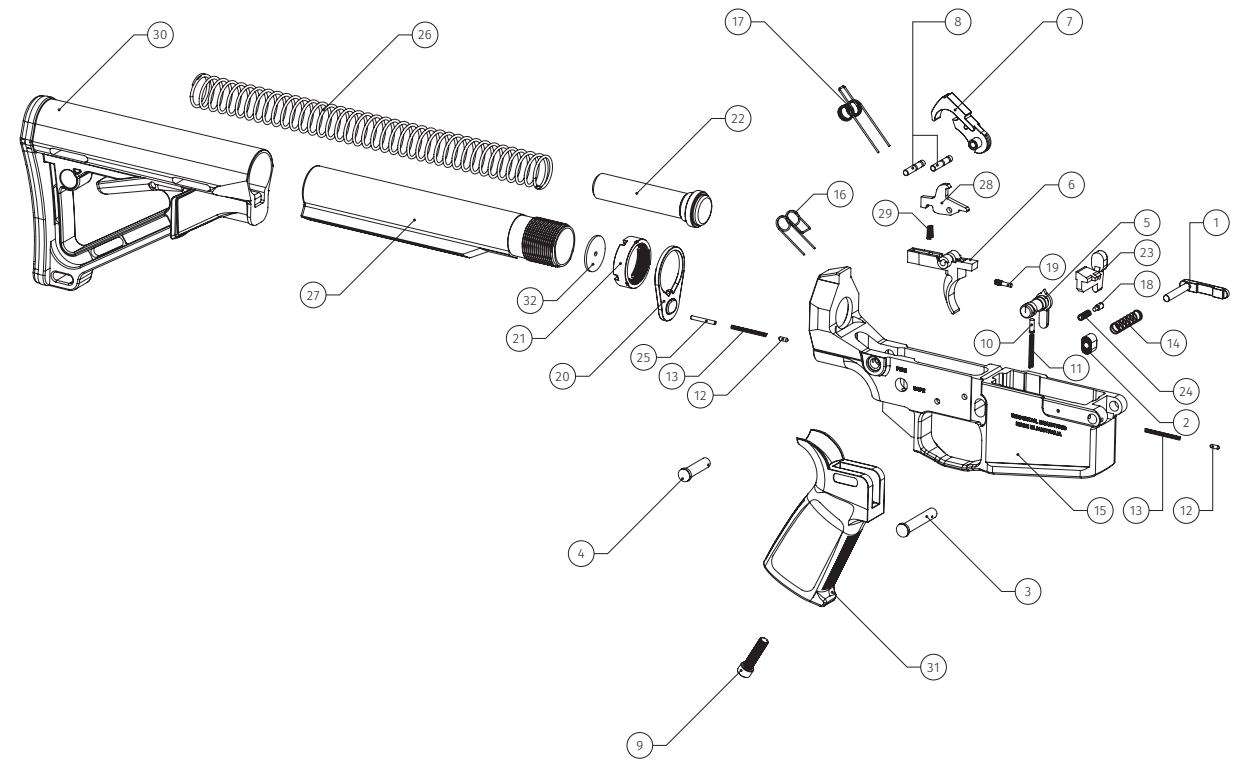

ITEM #	PART #	PART DESCRIPTION	QTY
1	WT15-00-1001	AR15 MAGAZINE RELEASE CATCH	1
2	WT15-00-1000	AR15 MAGAZINE RELEASE BUTTON	1
3	WT25-00-1001	AR308 PIVOT PIN	1
4	WT25-00-1002	AR308 TAKEDOWN PIN	1
5	WT15-00-1003	AR15 SAFETY SELECTOR	1
6	WT15-00-1019	TRIGGER LEVER	1
7	WT15-00-1022	AR15 HAMMER	1
8	WT15-00-1021	AR15 TRIGGER PIN	2
9	WT15-00-1013	AR15 GRIP SCREW	1
10	WT15-00-1004	AR15 SELECTOR DETENT PIN	1
11	WT15-00-1005	AR15 SELECTOR DETENT SPRING	1
12	WT15-00-1007	AR15 TAKEDOWN PIN DETENT	2
13	WT15-00-1006	AR15 TAKEDOWN PIN DETENT SPRING	2
14	WT15-00-1010	AR15 MAGAZINE CATCH SPRING	1
15	MPR308-02-001	MPR308-02-001 LOWER RECEIVER	1
16	WT15-00-1020	TRIGGER LEVER SPRING	1

ITEM #	PART #	PART DESCRIPTION	QTY
17	WT15-00-1023	AR15 HAMMER SPRING	1
18	WT25-00-1022	AR15 BOLT CATCH PLUNGER	1
19	WT25-00-1003	BOLT CATCH PIVOT PIN	1
20	WT15-00-1062	AR15 ND PLATE	1
21	WT15-00-1016	AR15 CASTLE NUT	1
22	MPR308-02-021	MPR308 BUFFER	1
23	WT15-00-1011	AR308 CARRIER CATCH OEM	1
24	WT15-00-1012	AR15 BOLT CATCH PLUNGER SPRING	1
25	MPR308-00-1009	DOWEL PIN	1
26	WT15-00-1042	AR15 CARBINE LENGTH SPRING	1
27	WT25-00-1023	WT25-00-1023 RECEIVER EXTENSION A5	1
28	WT15-00-1017	TRIGGER DISCONNECTOR	1
29	WT15-00-1018	AR15 DISCONNECTOR SPRING	1
30	MPR308-00-8000	MAGPUL CTR	1
31	WT15-00-8017	MAGPUL GRIP	1
32	MPR308-02-040	BUFFER WASHER	1

UPPER RECEIVER ASSEMBLY - EXPLODED VIEW

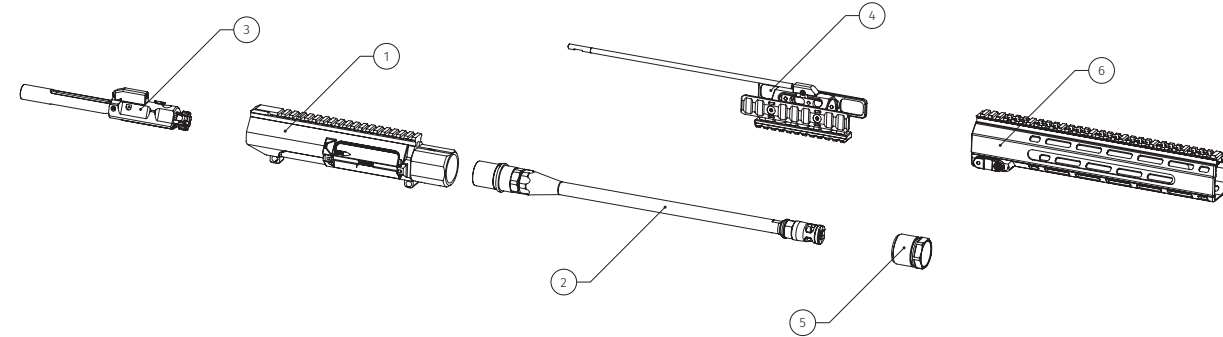

ITEM #	PART #	PART DESCRIPTION	QTY
1	MPR308-02-802	MPR308 UPPER RECEIVER SUB ASSEMBLY	1
2	MPR308-02-808	MPR308 BARREL ASSEMBLY	1
3	MPR308-02-803	MPR308 BOLT CARRIER ASSEMBLY	1
4	MPR308-02-805	MPR308 PUMP SHUTTLE ASSEMBLY	1
5	WT25-02-006	WT25 BARREL NUT	1
6	MPR308-02-804	MPR308 X-BOLT HAND GUARD 13	1

UPPER RECEIVER - EXPLODED VIEW

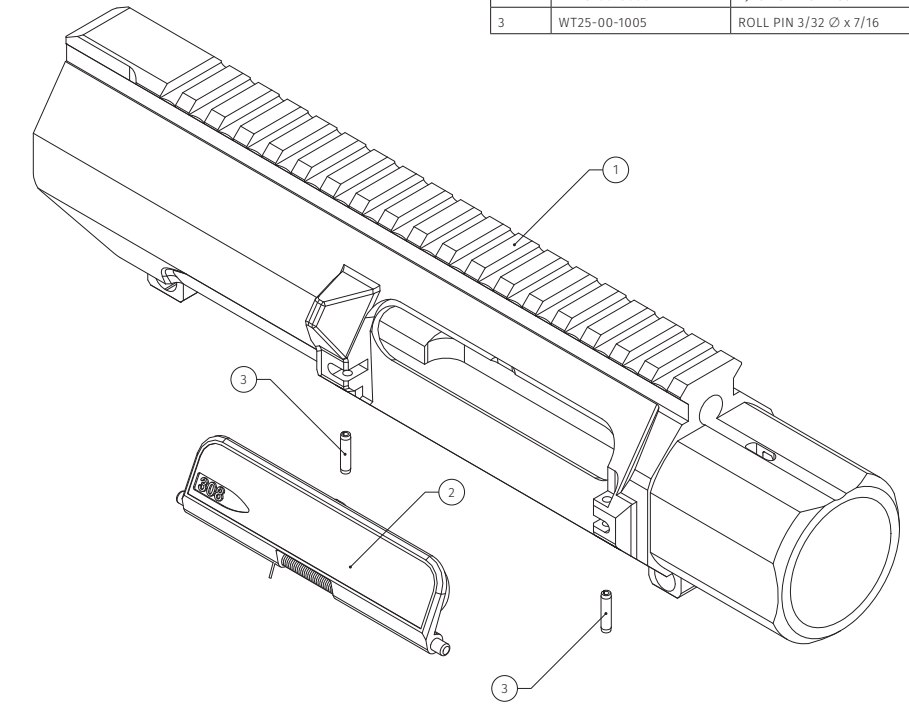

ITEM #	PART #	PART DESCRIPTION	QTY
1	MPR308-02-002	MPR308-02 UPPER RECEIVER	1
2	WT25-00-8000	EJECTION PORT COVER	1
3	WT25-00-1005	ROLL PIN 3/32 Ø x 7/16	2

HANDGUARD - EXPLODED VIEW

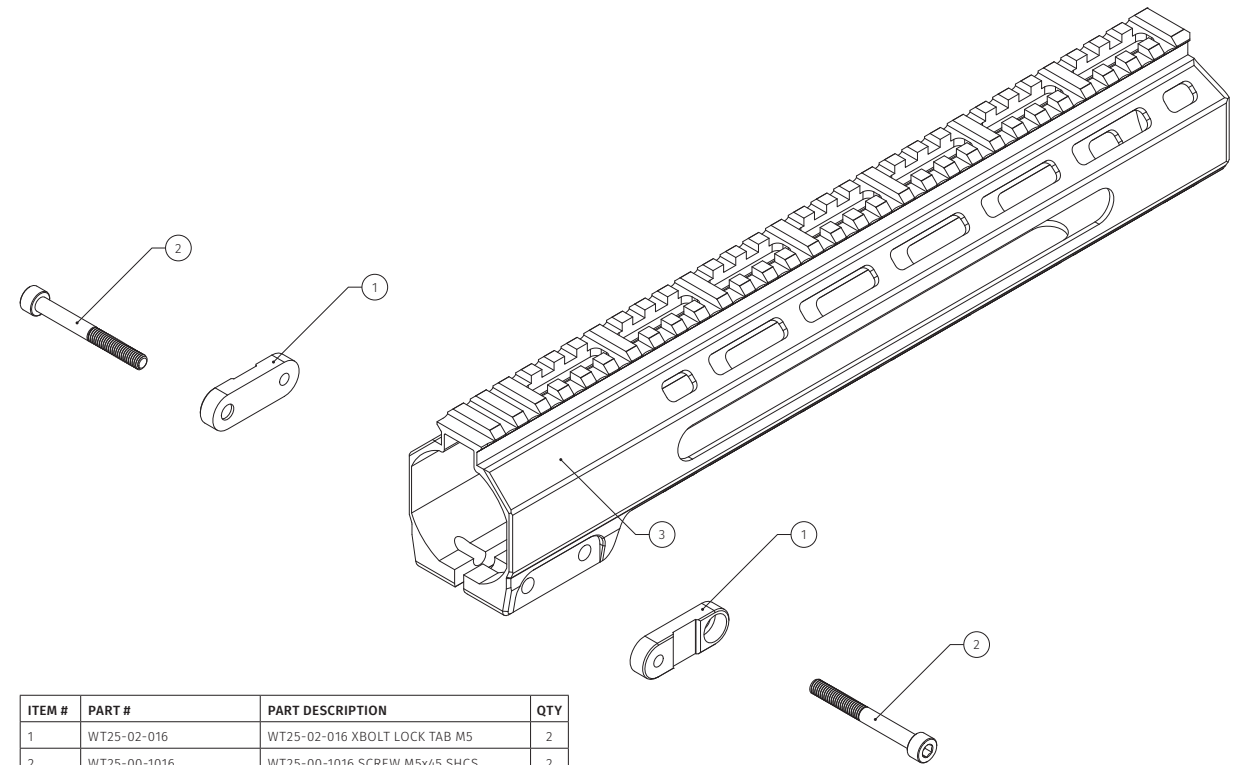

ITEM #	PART #	PART DESCRIPTION	QTY
1	WT25-02-016	WT25-02-016 XBOLT LOCK TAB M5	2
2	WT25-00-1016	WT25-00-1016 SCREW M5x45 SHCS	2
3	MPR308-02-022	MPR308-02 13" HAND GUARD	1

SHUTTLE ASSEMBLY - EXPLODED VIEW

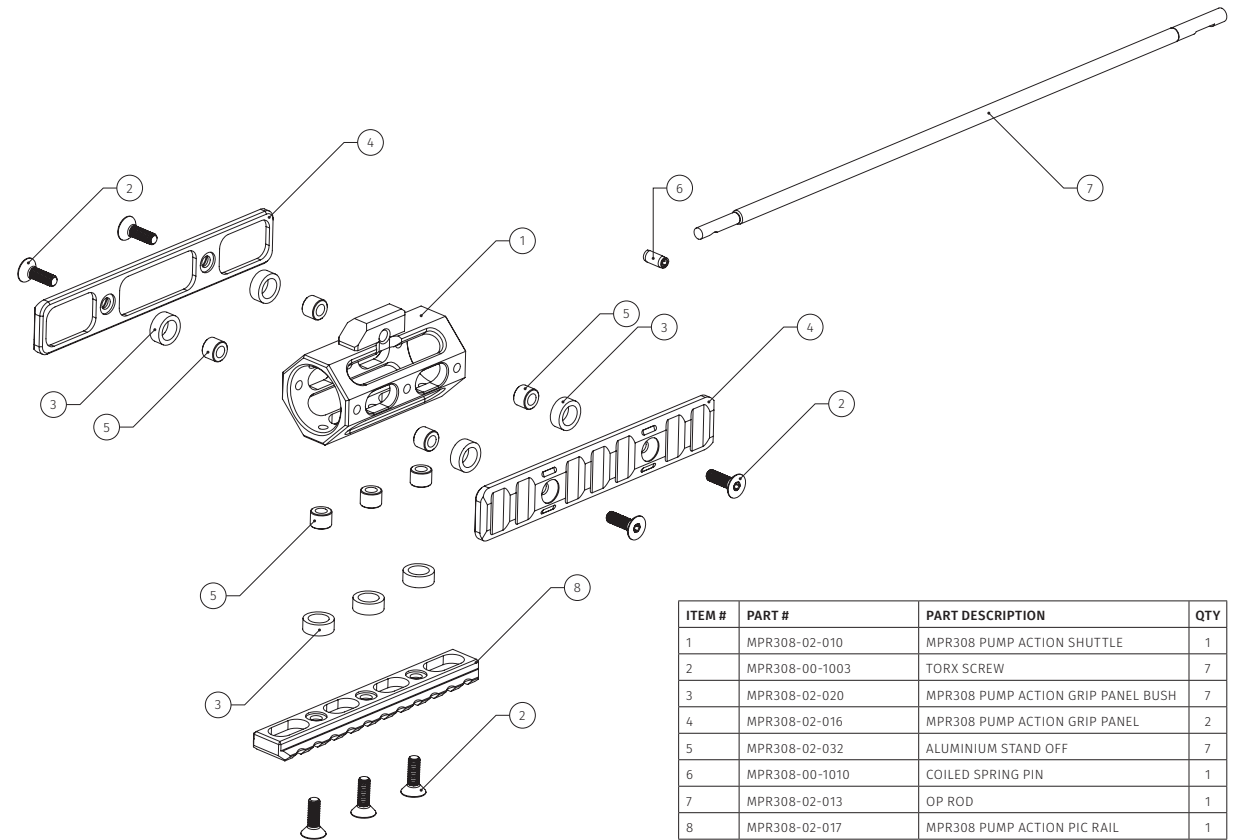

ITEM #	PART #	PART DESCRIPTION	QTY
1	MPR308-02-010	MPR308 PUMP ACTION SHUTTLE	1
2	MPR308-00-1003	TORX SCREW	7
3	MPR308-02-020	MPR308 PUMP ACTION GRIP PANEL BUSH	7
4	MPR308-02-016	MPR308 PUMP ACTION GRIP PANEL	2
5	MPR308-02-032	ALUMINIUM STAND OFF	7
6	MPR308-00-1010	COILED SPRING PIN	1
7	MPR308-02-013	OP ROD	1
8	MPR308-02-017	MPR308 PUMP ACTION PIC RAIL	1

**BOLT CARRIER GROUP - EXPLODED VIEW**

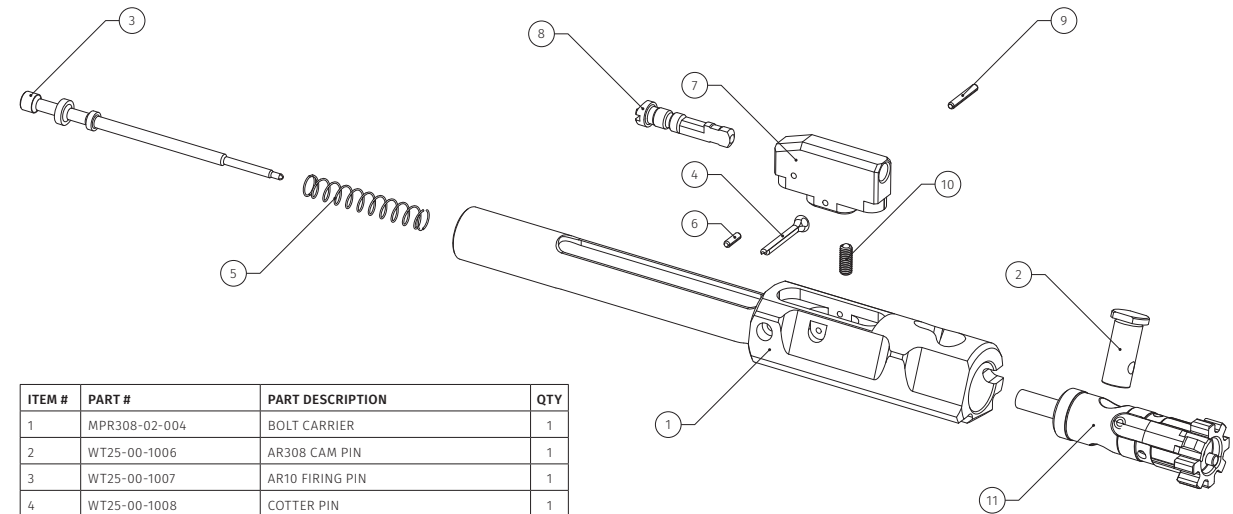

ITEM #	PART #	PART DESCRIPTION	QTY
1	MPR308-02-004	BOLT CARRIER	1
2	WT25-00-1006	AR308 CAM PIN	1
3	WT25-00-1007	AR10 FIRING PIN	1
4	WT25-00-1008	COTTER PIN	1
5	MPR308-02-011	SPRING	1
6	MPR308-00-1004	ROLL PIN	1
7	MPR308-02-028	MPR308 BOLT CARRIER OP ROD KEY	1
8	MPR308-02-027	PUSH ROD LOCK	1
9	MPR308-00-1007	SLOTTED SPRING PIN	1
10	MPR308-00-1008	ALLOY STEEL BALL-POINT SET SCREW	1
11	MPR308-02-806	MPR308 BOLT ASSEMBLY	1

**BOLT GROUP - EXPLODED VIEW**

ITEM #	PART #	PART DESCRIPTION	QTY
1	MPR308-02-030	MPR308-02 HELCAM BOLT	1
2	MPR308-00-1011	PIN EXTRACTOR SPIROL Ø 3mm x 12mm L	1
3	WT25-00-1009	WT25 EJECTOR PLUNGER	1
4	WT25-00-1010	WT25 EXTRACTOR	1
5	WT25-00-1012	WT25 EJECTOR PLUNGER SPRING	1
6	WT25-00-1013	AR308 EXTRACTOR SPRING	1
7	WT25-00-1015	1/16" x 3/8" ROLL PIN	1

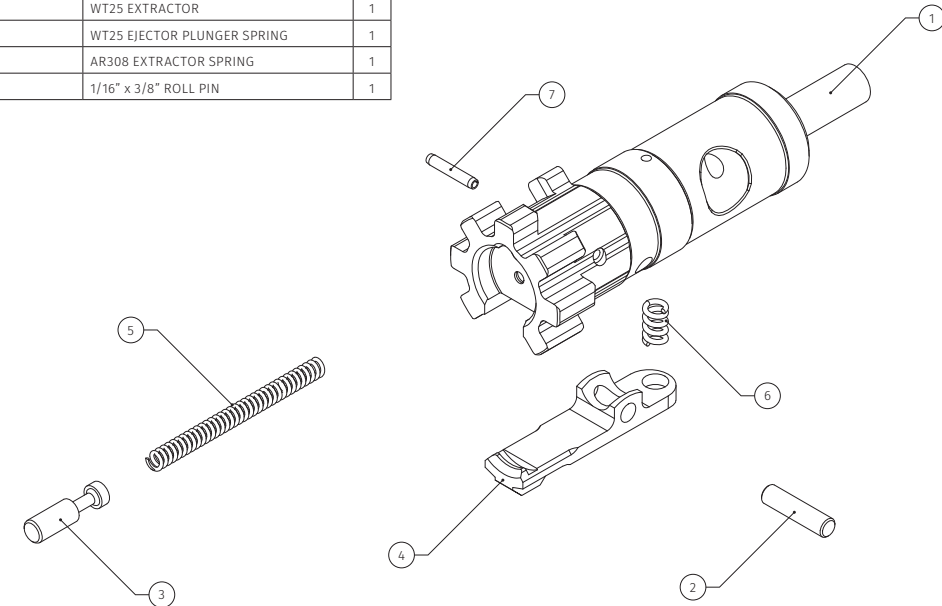

**NINOX MUZZLE BRAKE - EXPLODED VIEW**

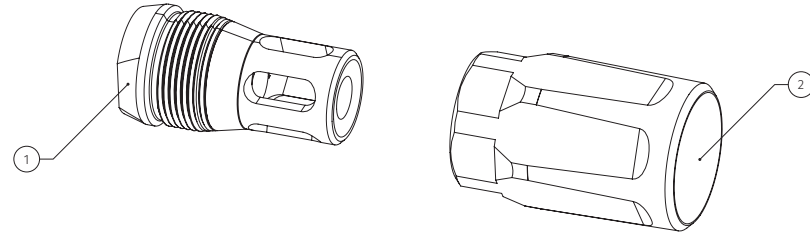

ITEM #	PART #	PART DESCRIPTION	QTY
1	WT01-03-004	NINOX MUZZLE BRAKE 5/8-24*	1
2	WT01-03-007	WEDGETAIL NINOX QD BLAST JACKET*	1

\*THIS IS A NONSTANDARD OPTIONAL ACCESSORY

**NOTE: AT NO STAGE SHOULD AN OWNER ATTEMPT TO DISASSEMBLY THE RIFLE, ITS SUBASSEMBLIES AND BOLT CARRIER GROUP ANY FURTHER THAN WHAT IS DEPICTED IN THESE IMAGES.**

**ONLY A SUITABLY QUALIFIED GUNSMITH SHOULD CONDUCT FURTHER DETAILED DISASSEMBLY OF THE MPR308 RIFLE. DAMAGE TO PARTS, LOSS OF PARTS OR INCORRECT REASSEMBLY MAY CAUSE DAMAGE TO THE FIREARM OR ITS INTERNAL PARTS.**

**THIS CONDITION COULD RESULT IN SERIOUS INJURY OR DEATH TO YOURSELF OR OTHERS.**

### 13.0 WARRANTY INFORMATION

Wedgetail Industries™ products are warranted to be free from defective materials and workmanship for life of the original purchaser.

Wedgetail Industries™ obligation under this warranty shall be limited to:

1. repairing or
2. Replacing any product upon inspection at Wedgetail Industries™ and based on its discretion

This warranty is limited and does not extend to: careless handling, abuse and misuse, unauthorised adjustments or modifications, use of improper ammunition, excessive or unreasonable use, ordinary wear & tear, rust or corrosion, and barrel obstruction.

Repairs are warranted for the duration of the original warranty and applies only to factory built products.

#### EXCLUSIVE REMEDY

The remedies in this section and in the warranty agreement constitute the sole and exclusive remedies of any authorised customer, as well as its successors and assigns, for any defect in the product.

#### DISCLAIMER

The warranty stated in this agreement is the sole and exclusive warranty pertaining to the product. Wedgetail Industries™ disclaims any warranty, express or implied, including, without limitation, any warranty of merchantability or fitness for a particular purpose. In no event shall Wedgetail Industries™ be responsible for any indirect, incidental or consequential damages including, without limitations, lost profits, costs of delay, with respect to economic loss or injury to property or to third parties, whether as a result of breach of express or implied warranty, negligence or otherwise.

Prior to returning any Wedgetail Industries™ product for warranty work, you must receive return material authorisation (RMA) from our customer service department.

Wedgetail Industries™ accepts no responsibility for items lost or damaged in shipping.

Items that are returned and found to be out of warranty will be repaired at the customer's expense; however, no work will be performed without the customer's written authorisation.

#### EXPORT CONTROL

User acknowledges that any technical data furnished by Wedgetail Industries™ in connection with this order may be subject to export control laws, including but not limited to the DECO Export Control Regulations and the International Traffic in Arms Regulations.

In this regard, User agrees that, unless it has obtained prior written consent from the Defence Export Control Office (DECO) they will not export, re-export, or trans-ship, directly or indirectly, the goods, documentation, technical assistance, or any media in which any of the foregoing is contained, or other technology provided hereunder or the direct product thereof, to any country or citizen.

### CONTACT INFORMATION

Hours  
Monday – Friday 10am to 4pm AEST

#### Customer Service Department

Phone  
1300 089 958

Email  
[sales@wedgetailindustries.com](mailto:sales@wedgetailindustries.com)

No part of this document may be copied, reproduced, or transmitted by any means, for any purpose without prior written permission from Wedgetail Industries™.

All images and text copyright 2024 Wedgetail Industries™











 **WEDGETAIL**  
INDUSTRIES

