

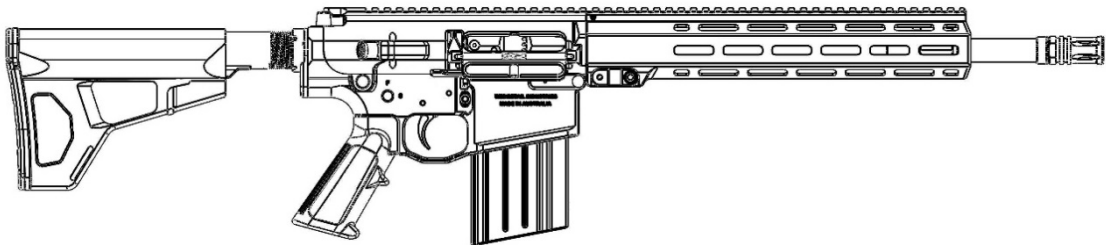

WEDGETAIL
INDUSTRIES

WT25-02 SEMI-AUTOMATIC RIFLE

MANUAL



COVERING ALL VARIANTS OF THE WT25-02 RIFLE SYSTEM

This SAFETY & INSTRUCTION MANUAL should always accompany this firearm and be transferred with it upon change of ownership or when presented to another person.

A copy of this manual is available from www.wedgetailindustries.com.

INTRODUCTION

Thank you for purchasing a Wedgetail Industries WT25 gas operated semi-automatic rifle. Wedgetail Industries is proud to be the pre-eminent manufacturer of semi-automatic rifles in Australia. When you purchase a Wedgetail Industries rifle you are helping to maintain Australian advanced manufacturing businesses and enhance the vital sovereign capability of manufacturing small arms in Australia.

Our goal for the WT25 was to design, manufacture and support an Australian made self-loading rifle. The WT25 is based on the proven AR15/SR25 architecture of modular upper and lower receiver sub-assemblies with excellent ergonomics. The result is a rifle system that is highly reliable, accurate and durable.

The highest quality materials and finishes are used in the manufacture of the WT25. When maintained correctly, the WT25 will provide many years of reliable service. To support this goal we maintain a complete supply of parts for the WT25 in Australia, ready to dispatch. Please refer to the parts list and drawings and the back of this manual.

You may be a new semi-automatic rifle owner or a seasoned professional, but it is vital that you maintain operational safety as your highest concern. When using any semi-automatic firearm, there is one critical safety point you must always keep in mind:

The rifle re-loads itself every time you fire!

This may seem obvious, but you must be always aware of this simple rule. When you do not immediately want to fire another round, always remember to remove the last loaded round from the chamber of the rifle by drawing the charging handle rearward and locking the bolt open and place the rifle on safe. Remember the rifle can fire without the magazine inserted if there is a round left in the chamber.

We hope you find the WT25 to be a useful and reliable tool. Please feel free to contact us via email at sales@wedgetailindustries.com if you have any questions about the rifle or any of the information in this manual.

Contents







1.0	ABOUT THIS MANUAL.....	5
1.1	WARNINGS AND SAFETY DATA	5
1.2	NOTES ON AMMUNITION	6
2.0	GENERAL DESCRIPTION OF THE WT25.....	8
2.1	WT25 TECHNICAL DATA.....	9
2.2	RIFLE NOMENCLATURE AND ASSEMBLY DRAWINGS.....	10
3.0	HOW THE WT25 WORKS	14
4.0	HOW TO USE THE WT25	16
4.1	SAFETY.....	16
4.4	THE OPERATING CONDITIONS OF THE WT25	18
4.5	OPERATING CONTROLS.....	19
4.6	CHANGING BETWEEN OPERATING CONDITIONS ON THE WT25.....	24
4.7	CLEARING THE RIFLE	25
5.0	FIRST FIRING OF THE WT25.....	28
5.1	CLEANING BEFORE FIRING	28
5.2	LOADING THE MAGAZINE	29
6.0	TROUBLESHOOTING.....	34
6.1	IDEAL EJECTION PATTERN	34
6.2	CLEARING STOPPAGES AND MALFUNCTIONS.....	34
7.0	MAINTENANCE:.....	35
7.1	FIELD STRIPPING AND DISASSEMBLY:.....	35
8.0	CLEANING AND ENVIRONMENTAL CARE INSTRUCTIONS:.....	40
8.6	TEST AFTER REASSEMBLY.....	42
8.7	ROUTINE OPERATOR’S MAINTENANCE	43
9.0	USING THE WT25 IN EXTREME ENVIRONMENTS.....	44
10.0	SUPPRESSOR USE	45
11.0	TROUBLE SHOOTING	46
12.0	WARRANTY INFORMATION.....	47
13.0	CONTACT INFORMATION.....	48
14.0	WT25 MAINTENANCE SCHEDULE	49
15.0	PARTS LISTS AND DRAWINGS	50





1.0 ABOUT THIS MANUAL

The purpose of this manual is to provide information on the operation and safe use of the WT25 rifle. The manual also provides instruction on user level maintenance of the rifle.

Make sure that you read this manual carefully and understand the information in it before to operating the rifle.

1.1 WARNINGS AND SAFETY DATA

	WARNING! NEVER ALLOW A FIREARM TO BE USED BY INDIVIDUALS WHO DO NOT UNDERSTAND ITS SAFE OPERATION.
	WARNING! SAFETY IS YOUR NUMBER ONE RESPONSIBILITY. THE FIRST CONCERN OF EVERY FIREARM OPERATOR SHOULD BE SAFETY. ENSURE YOU READ THE INSTRUCTIONS AND IF YOU FEEL UNCERTAIN ABOUT ANY OPERATIONAL ASPECTS OF YOUR FIREARM, PLEASE CONTACT WEDGETAIL INDUSTRIES AT SALES@WEDGETAILINDUSTRIES.COM
	WARNING! ALWAYS KEEP THE MUZZLE POINTED IN A SAFE DIRECTION WHEN LOADING, UNLOADING, CLEARING OR CHARGING THE RIFLE
	WARNING! NEVER POINT A FIREARM ANYTHING YOU DO NOT INTEND TO SHOOT WHETHER OR NOT IT IS LOADED. ALWAYS TREAT EVERY FIREARM AS IF IT IS LOADED AND WILL FIRE.
	WARNING! IF THE FIREARM BECOMES IMMERSSED IN WATER, MAKE SURE YOU CLEAN AND DRY THE BARREL CAREFULLY BEFORE FIRING. NEVER FIRE THE RIFLE WITH WATER OR ANY OTHER OBSTRUCTION IN THE BORE.
	WARNING! THE ADJUSTABLE GAS BLOCK AND BARREL WILL BECOME HOT ENOUGH TO CAUSE INJURY DURING FIRING. TAKE CARE TO AVOID TOUCHING THE BARREL OR THE GAS BLOCK WHEN CHANGING GAS BLOCK SETTINGS. ALWAYS KEEP YOUR FIREARM POINTED IN A SAFE DIRECTION. ONLY CHANGE THE GAS BLOCK SETTIGNGS WHEN THE RIFLE IS UNLOADED.
	WARNING! ALWAYS USE THE CORRECT AMMUNITION IN GOOD CONDITION FOR YOUR PARTICULAR FIREARM AS INDICATED BY THE MARKING ON THE FIREARM. NEVER USE NON-STANDARD, RELOADED, OR “HAND-LOADED” AMMUNITION.

	<p>WARNING! BEWARE OF BARREL OBSTRUCTIONS. BE SURE THE BARREL IS CLEAR OF OBSTRUCTIONS BEFORE SHOOTING. MUD, WATER, SNOW OR OTHER OBJECTS MAY INADVERTENTLY LODGE IN THE BARREL BORE. A SMALL OBSTRUCTION CAN CAUSE A DANGEROUS INCREASE IN PRESSURE AND MAY DAMAGE YOUR FIREARM AND CAUSE INJURY TO YOURSELF AND OTHERS</p>
	<p>WARNING! BE SURE ALL ACCESSORIES, SUCH AS GRIPS, SLINGS, SCOPES AND OTHER ACCESSORIES ARE COMPATIBLE WITH THE FIREARM AND THAT THE ACCESSORIES DO NOT INTERFERE WITH SAFE OPERATION. IT IS YOUR RESPONSIBILITY TO UNDERSTAND AND FOLLOW ALL OF THE INSTRUCTIONS IN THIS MANUAL, AS WELL AS THOSE WHICH MAY BE SUPPLIED WITH YOUR AMMUNITION AND ANY ACCESSORY</p>
	<p>WARNING! NEVER DISASSEMBLE YOUR FIREARM BEYOND THE '<u>FIELD STRIPPING PROCEDURE</u>' OUTLINED IN THIS MANUAL. IMPROPER DISASSEMBLY OR REASSEMBLY OF YOUR FIREARM MAY BE DANGEROUS AND CAN LEAD TO SERIOUS INJURY OR DEATH.</p>
	<p>WARNING! NEVER LOAD OR CYCLE LIVE AMMUNITION IN YOUR FIREARM ANYWHERE YOU WOULD NOT WANT TO FIRE THE FIREARM. LOADING LIVE AMMUNITION INTO A FIREARM IN A RESIDENTIAL AREA OR DWELLING IS EXTREMELY DANGEROUS. ONLY PRACTICE LOADING LIVE ROUNDS ON A FIRING RANGE OR OTHER SAFE PLACE TO FIRE A FIREARM. INSTEAD, USE INERT, 'DRILL ROUNDS' TO PRACTICE LOADING AND UNLOADING THE FIREARM.</p>

1.2 NOTES ON AMMUNITION



A firearm and ammunition are a system and must work together. There are different types of ammunition for different types of firearms. Your firearm has been designed for ammunition of a specific type and a specific gauge or calibre. It is important to select the proper ammunition for your firearm.

Locate the cartridge designation marked on the firearm receiver. This information indicates the correct ammunition that must be used in your firearm. You are responsible for selecting ammunition that meets industry standards and is appropriate in type and calibre for this firearm.

Wedgetail Industries recommends the use of .308 Win polymer tipped projectile ammunition from reputable ammunition manufacturers only. Wedgetail Industries does not recommend the use of soft point projectile ammunition or ammunition that uses Sierra 'GameKing' projectiles in the WT25;

Note: The WT25 (.308 Win) was tested at the factory using ammunition from the following manufacturers:

- Australian Outback Ammunition .308 Win 168Gr Sierra HPBT 'MatchKing'
- Hornady .308 Win 168Gr A-MAX® SPF
- Federal .308 Win 175Gr 'MatchKing' Gold Medal
- Federal American Eagle .308 Win 130 Grain JHP

	<p>WARNING: NEVER USE AMMUNITION OF THE INCORRECT GAUGE OR CALIBRE. USING AMMUNITION OF THE INCORRECT GAUGE OR CALIBER MAY CAUSE DAMAGE TO YOUR FIREARM AND POSSIBLE SERIOUS INJURY TO YOU AND TO OTHERS. WARNING: NEVER USE CARTRIDGES OTHER THAN THOSE DESIGNATED BY THE MARKING ON THE FIREARM. DOING SO CAN RESULT IN DANGEROUSLY HIGH PRESSURES THAT MAY DAMAGE THE FIREARM AND POSSIBLY CAUSE SERIOUS INJURY TO YOURSELF AND OTHERS</p>
	<p>WARNING: NEVER USE AMMUNITION NOT SPECIFICALLY DESIGNATED FOR USE IN YOUR FIREARM. FAILURE TO USE THE CORRECT TYPE OR CALIBER OF AMMUNITION MAY CAUSE THE FIREARM TO JAM, OR FAIL TO FIRE, OR MAY GENERATE EXCESSIVE PRESSURE WHICH CAN DAMAGE OR EVEN RUPTURE YOUR FIREARM, CAUSING PERSONAL INJURY OR DEATH TO THE SHOOTER OR BYSTANDERS</p>
	<p>WARNING: DEATH, SERIOUS INJURY AND PROPERTY DAMAGE CAN RESULT FROM THE USE OF INCORRECT AMMUNITION OR BORE OBSTRUCTIONS. NEVER USE RELOADED AMMUNITION.</p>

2.0 GENERAL DESCRIPTION OF THE WT25

The WT25 rifle series are designed and manufactured in Australia. The WT25 rifle is a gas operated, rotary bolt, magazine-fed, air-cooled, self-loading rifle chambered in .308 Winchester.

The WT25 rifles have the following characteristics:

- 2-stage trigger
- 16 position adjustable gas system with positive adjustment detents
- Nickel Teflon coated bolt carrier for reduced friction and ease of cleaning
- Australian made match grade barrels, nitride coated internally and externally for increased barrel life
- Magpul AR15 grip
- Magpul AR15 butt stock
- Free-floating hand guard with M-LOK accessory slots
- Ambidextrous magazine release and bolt release

The WT25 is fitted with medium-heavy profile barrel in either 16 inch (406mm) or 20 inch (508mm) lengths. The twist rate is 1:10.

2.1 WT25 TECHNICAL DATA

WT25-02 16" BARREL

Calibre	.308 Winchester
Weight (unloaded w/o accessories)	4.25kg
Length (stock collapsed)	860mm
Barrel Length	16 inches (508mm)
Rifling	6 Lands & Grooves, 1:10" RH Twist
Magazine Capacity	20 rounds
Trigger Pull (semi)	5 lbs. (single stage trigger) 3.2-5.0 lbs. (1st stage – optional trigger) 0.5-1.5 lbs. (2nd stage – optional trigger)
Sustained rate of fire	50 rounds per minute
Range	>700 meters

WT25-02 20" BARREL

Calibre	.308 Winchester
Weight (unloaded w/o accessories)	4.4kg
Length (stock collapsed)	960mm
Barrel Length	20 inches (508mm)
Rifling	6 Lands & Grooves, 1:10" RH Twist
Magazine Capacity	20 rounds
Trigger Pull (semi)	5 lbs. (single stage trigger) 3.2-5.0 lbs. (1st stage – optional trigger) 0.5-1.5 lbs. (2nd stage – optional trigger)
Sustained rate of fire	50 rounds per minute
Range	>700 meters

NOTE: Changes to the factory configuration of the WT25 rifle by the end-user, including but not limited to, changes in barrel length, calibre, trigger mechanism, and recoil system may void the manufacturer's warranty.

It is your responsibility to comply with all state and federal firearm laws and regulations regarding the possession, transport, or modification of this product.

2.2 RIFLE NOMENCLATURE AND ASSEMBLY DRAWINGS

1. Muzzle Device
2. Barrel Assembly
3. Gas Block (under handguard)
4. Handguard, X-bolt with MLOK slots
5. Upper Receiver
6. Charging Handle
7. Safety Selector
8. Trigger
9. Ambidextrous Bolt Catch/Release
10. Butt stock Assembly
11. Forward Assist
12. Case Deflector
13. Ejection Port Cover
14. Front Pivot Pin
15. Rear Takedown Pin
16. Magazine
17. Magazine Release Button (both sides)
18. Lower Receiver
19. Pistol Grip
20. Magazine Well

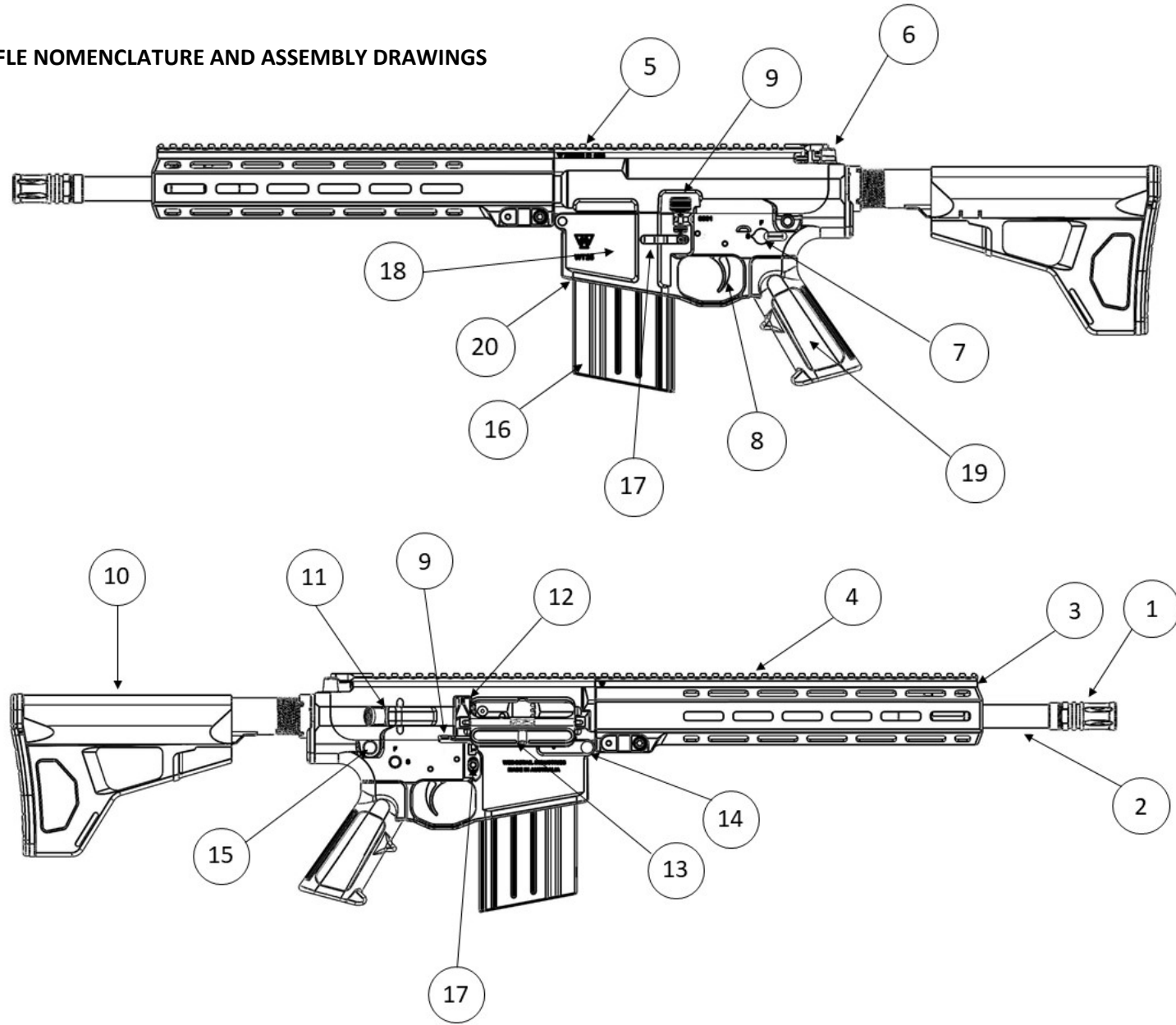

WT25 SUB-ASSEMBLIES

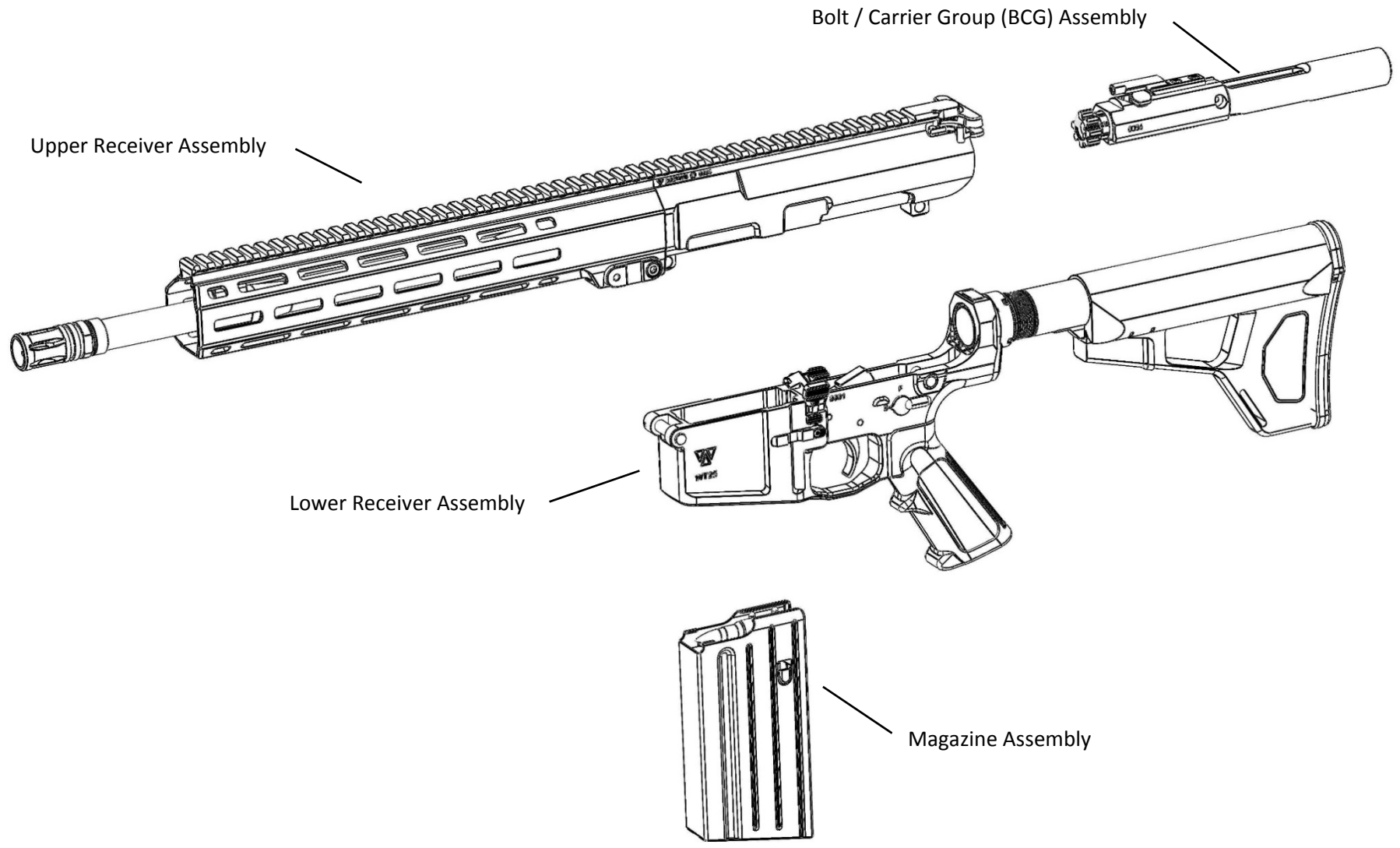

BOLT CARRIER GROUP SUB ASSEMBLY

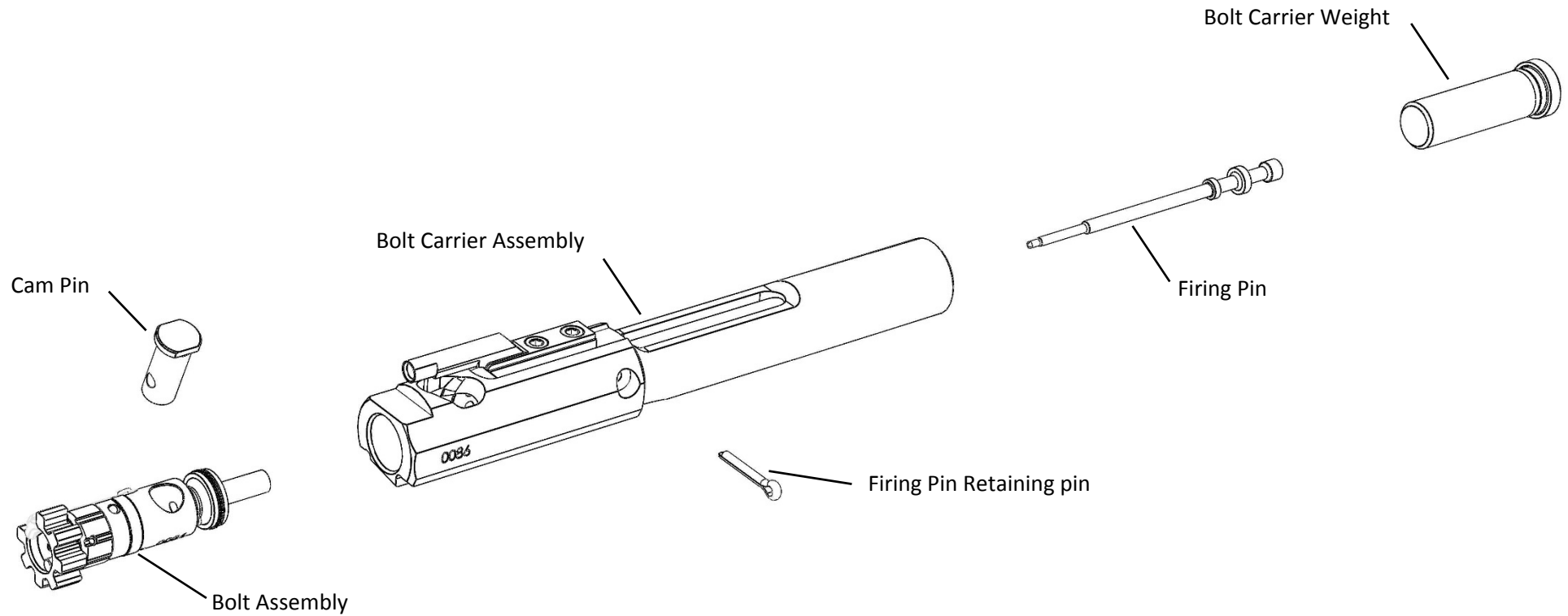

Magazine Assembly (type varies with availability)

NOTE: AT NO STAGE SHOULD AN OWNER ATTEMPT TO DISASSEMBLY THE RIFLE, ITS SUB-ASSEMBLIES AND BOLT CARRIER GROUP ANY FURTHER THAN WHAT IS DEPICTED IN THESE IMAGES.

ONLY A SUITABLY QUALIFIED GUNSMITH SHOULD CONDUCT FURTHER DETAILED DISASSEMBLY OF THE WT25 RIFLE. DAMAGE TO PARTS, LOSS OF PARTS OR INCORRECT REASSEMBLY MAY CAUSE DAMAGE TO THE FIREARM OR ITS INTERNAL PARTS.

THIS CONDITION COULD RESULT IN SERIOUS INJURY OR DEATH TO YOURSELF OR OTHERS.

3.0 HOW THE WT25 WORKS

To safely use the WT25, you must understand how the WT25 works. By understanding how all the parts function, you will be able to recognise malfunctions and fix them.

You will also be able to tell when a part is missing, worn, or damaged by examining the rifle.

The WT25 uses gas from the fired cartridge to move the bolt and carrier group rearwards against the recoil spring. The recoil spring is housed in the buffer tube. The stock is also mounted onto the buffer tube.

Starting from a live round in the chamber, the cycle of operation of the WT25 is described in the following sequence:

- 1 Firing:** When the trigger is squeezed it rotates around the trigger pin and disengages from the notch on the hammer.

The hammer is thrown forwards by the action of the hammer spring to strike the firing pin through the bolt.

The tip of the firing pin is forced through the central hole in the face of the bolt and strikes the round. This ignites the primer which in turn ignites the cartridge powder.

The gas generated by the rapid burning of the cartridge powder forces the projectile through the barrel.

As the bullet passes the gas port, and before the bullet leaves the barrel, a portion of the gas enters the gas port and flows along the gas tube where it is directed into the gas key mounted onto the bolt carrier.

- 2 Unlocking:** The gas enters the bolt carrier key and flows down into the space behind the bolt. The bolt gas rings prevent gas from flowing out into the receiver between the bolt and carrier. The gas pressure makes the bolt carrier move to the rear. As the bolt carrier moves to the rear, the bolt cam pin follows the path of the cam track. This causes the bolt to rotate and unlock.

When the bolt is fully unlocked, the bolt lugs line up with the slots in the barrel extension and the bolt moves rearwards.

- 3 Extracting:** As the bolt and bolt carrier move to the rear, the extractor, which is attached to the bolt head, withdraws the cartridge case from the chamber.
- 4 Ejecting:** As the bolt moves rearward, the spent case clears the receiver and is forced out the ejection port opening by the spring loaded ejector plunger.
- 5 Cocking:** The continued rearward action of the bolt rides over the hammer forcing it to rotate downward into the lower receiver. The hammer catches on the disconnecter mounted to the trigger. When the trigger is released, the hammer is released from the disconnecter and catches on the trigger sear. This action re-cocks the rifle. The rearward movement of the bolt is arrested by the recoil spring.
- 6 Feeding:** As soon as the bolt has moved rearward and the recoil spring is fully compressed, the recoil spring propels the bolt forwards again. The magazine supplies another cartridge into position ready to be fed into the chamber.
- 7 Chambering:** The compressed action spring in the buffer assembly forces the bolt towards the chamber. The lower two lugs of the bolt strike the base of the top round in the magazine and move it forwards and out of the magazine. As the bolt continues forward, the round is guided into the chamber by the feed ramp. When the round is fully chambered, the extractor overrides and grips the cannelure (groove at the base of the cartridge) of the round. The ejector plunger is depressed into the bolt face against the spring.
- 8 Locking:** At the end of the forward movement of the bolt carrier, the bolt cam pin is forced by the bolt carrier cam track to rotate the bolt head and lock the bolt into the barrel extension. The rifle is then ready to fire again.

4.0 HOW TO USE THE WT25

4.1 SAFETY

To safely use the WT25, the operator must be aware of the following at all times.

1. The rules of firearms safety including wearing correct PPE.
2. The operating condition of the WT25, that is, whether there are rounds in the magazine, rounds in the chamber, and the position of the manual safety.
3. How to use each control to change from one operating condition to another that is to load a magazine, chamber a round, apply the safety catch, fire the rifle, unload a chambered round without firing the round, and remove the magazine.

4.2 The five rules of firearm safety

The five rules of firearm safety are as follows and should be familiar to all firearm owners:

1. **Treat every firearm as if it is loaded.** Any firearm handled by a person must be treated as if it is loaded and prepared to fire. Whether or not a firearm is loaded should not affect how a person handles the firearm in any instance.
2. **Never point the firearm at anything you do not want to shoot.** Firearm owners must be aware of the direction of their firearm's muzzle and what is in the path of the projectile if the firearm fires.

A person must ensure the path between the muzzle and target is clear of other people, equipment, buildings, or anything else that the person does not want to shoot.

3. **Keep the finger straight and off the trigger until ready to fire**

A person must not place their finger on the trigger unless they intend to fire the rifle. You are the most important safety feature of any firearm.

The WT25 has a strong and reliable mechanical safety, but a person must not rely solely on the mechanical safety for safe operation. You must always remember that any mechanical device can fail.

4. Identify positive identification of the target and its surroundings.

The disciplined shooter can positively identify the target and knows what is in front of and beyond the target.

You are responsible for all bullets that you fire from your rifle, including the bullet's final destination.

- 5. This rifle automatically re-loads itself after every shot and will fire without a magazine inserted.** You must never forget that the WT25 rifle will re-load a new cartridge instantly every time the trigger is pulled. The rifle will fire without the magazine inserted, if there is a round in the chamber of the rifle.

Whenever you have finished shooting, you must remove the magazine, manually open the bolt using the charging handle, and inspect the chamber to be sure that there are no rounds of ammunition in the chamber.

4.3 Wearing of correct PPE

Other than the obvious hazard of live fire, using the WT25 rifle exposes the user to the following hazards:

- 1. Combustion gasses.** Only use the WT25 in a well-ventilated area.
- 2. Lead contamination.** Wash your hands thoroughly after firing and handling the WT25.
- 3. Noise.** The WT25 is very loud when it fires. Always wear good quality, well fitted hearing protection when firing the WT25
- 4. Particles and gases escaping from the ejection port.** Always wear well fitted safety glasses rated for impacts when shooting the WT25.
- 5. Hot surfaces.** Parts of the WT25, particularly the barrel and gas system, will get hot enough to cause serious burns if you touch those parts with bare skin. Always allow the parts of the WT25 to cool before touching them.

4.4 THE OPERATING CONDITIONS OF THE WT25

The WT25 has four main operating conditions:

1. Magazine containing rounds inserted into the rifle, no rounds in the chamber. (MAGAZINE LOADED).
2. Magazine containing rounds in the rifle, round in the chamber, safety on. (READY TO FIRE)
3. Magazine loaded, round in the chamber, safety off. (SAFETY OFF)
4. No magazine loaded, no round in the chamber. (UNLOADED)

To use the WT25 safely and effectively, it is essential that you can:

1. Identify which condition the WT25 is in.
2. Know how to go from one condition to any other condition using the operating controls.

You should practice using all the operating controls of the rifle with no ammunition present, so you understand what the controls do and how to use them to put the WT25 in any one of the four operating conditions. The operating controls are described below. Refer to the drawings.

4.5 OPERATING CONTROLS

The main operating controls of the WT25 are the safety selector, the charging handle and the bolt release. All three controls can be used by left and right handed shooters. Familiarise yourself with the operating controls below and practice using them without any ammunition present.

SAFETY SELECTOR (7)

The safety selector is located on the lower receiver assembly above the pistol grip.

When the safety selector is set to **S**, the rifle is on **SAFE** and the hammer cannot fall, as per figure, below.

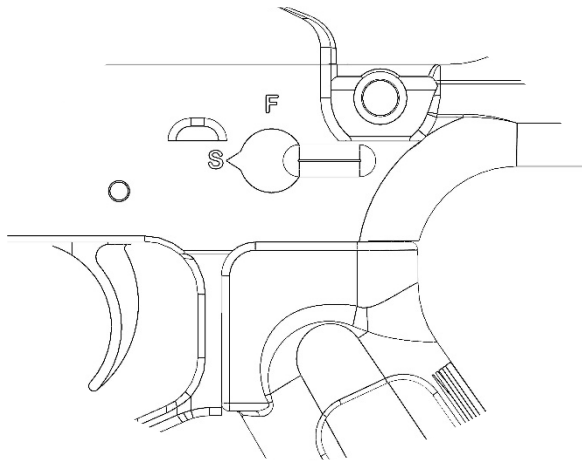

Rifle set on **S, SAFE**

When the safety selector is set to **F**, the rifle is on **FIRE** and the rifle will fire when the trigger is pulled, as per figure, below.

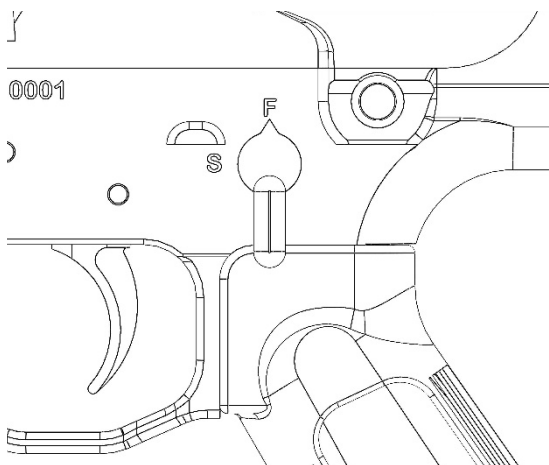

Rifle set on **F, FIRE**

NOTE: The rifle can only be set to S, SAFE, when the hammer is cocked, that is, when the bolt has been drawn back and let go.

Charging handle (6)

The charging handle is used to draw the bolt rearward. The charging handle has a protruding wing on both sides. Either the left side or the right side of the handle can be grasped. It is not necessary to hold both sides at once. The handle should be pulled straight back and all the way to the rear.

The charging handle should be pushed all the way forward after the bolt group is locked rearward.

The charging handle does not move when the rifle is fired. The bolt carrier group moves independently of the charging handle.

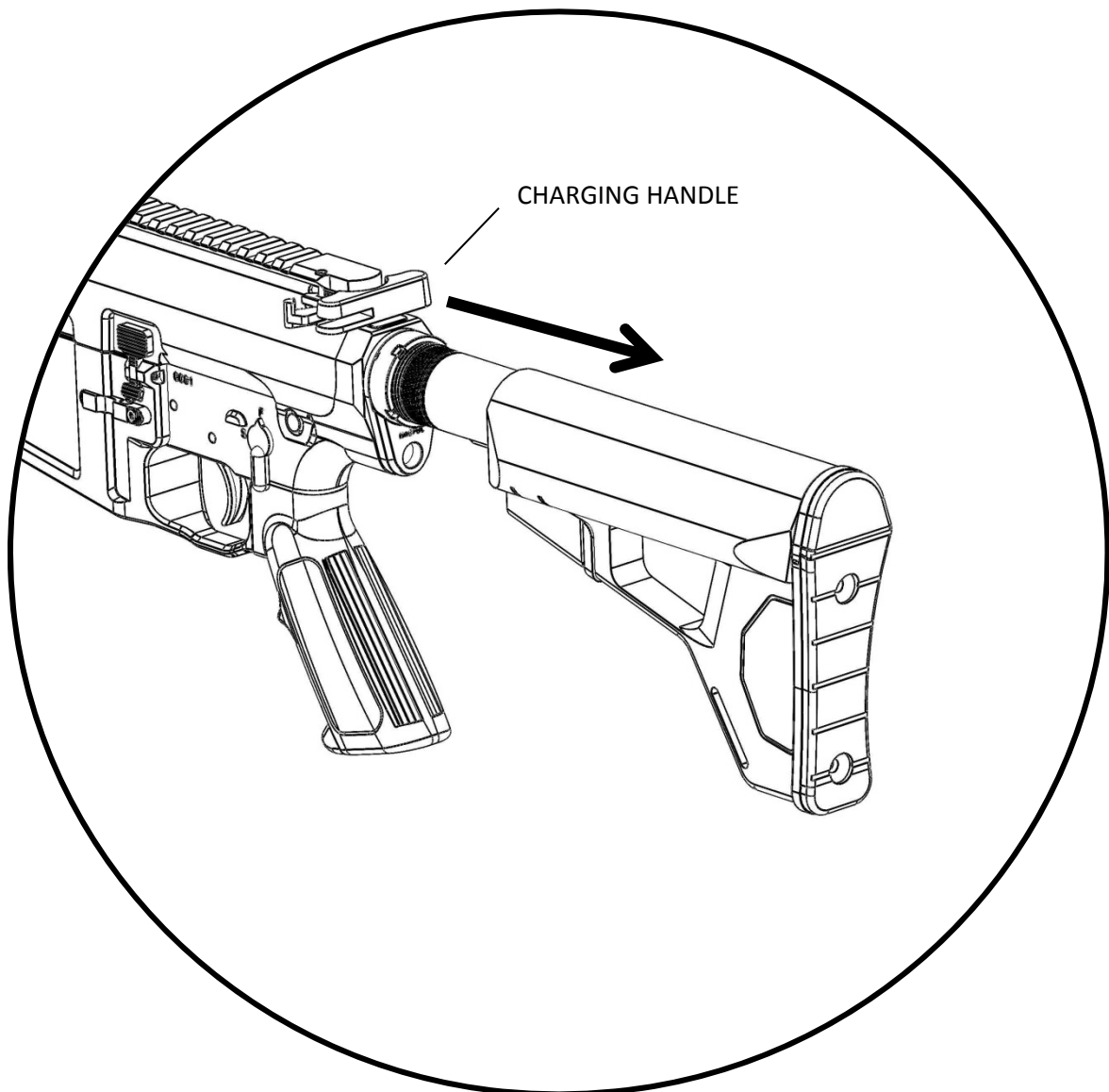

Bolt catch / release lever (9)

The bolt catch / release lever is used to keep the bolt and carrier group (BCG) held to the rear. It can be applied manually to keep the BCG rearward. The bolt catch also activates automatically when the magazine is empty. It will stay activated when the empty magazine is removed. The bolt catch can be activated from either side of the rifle.

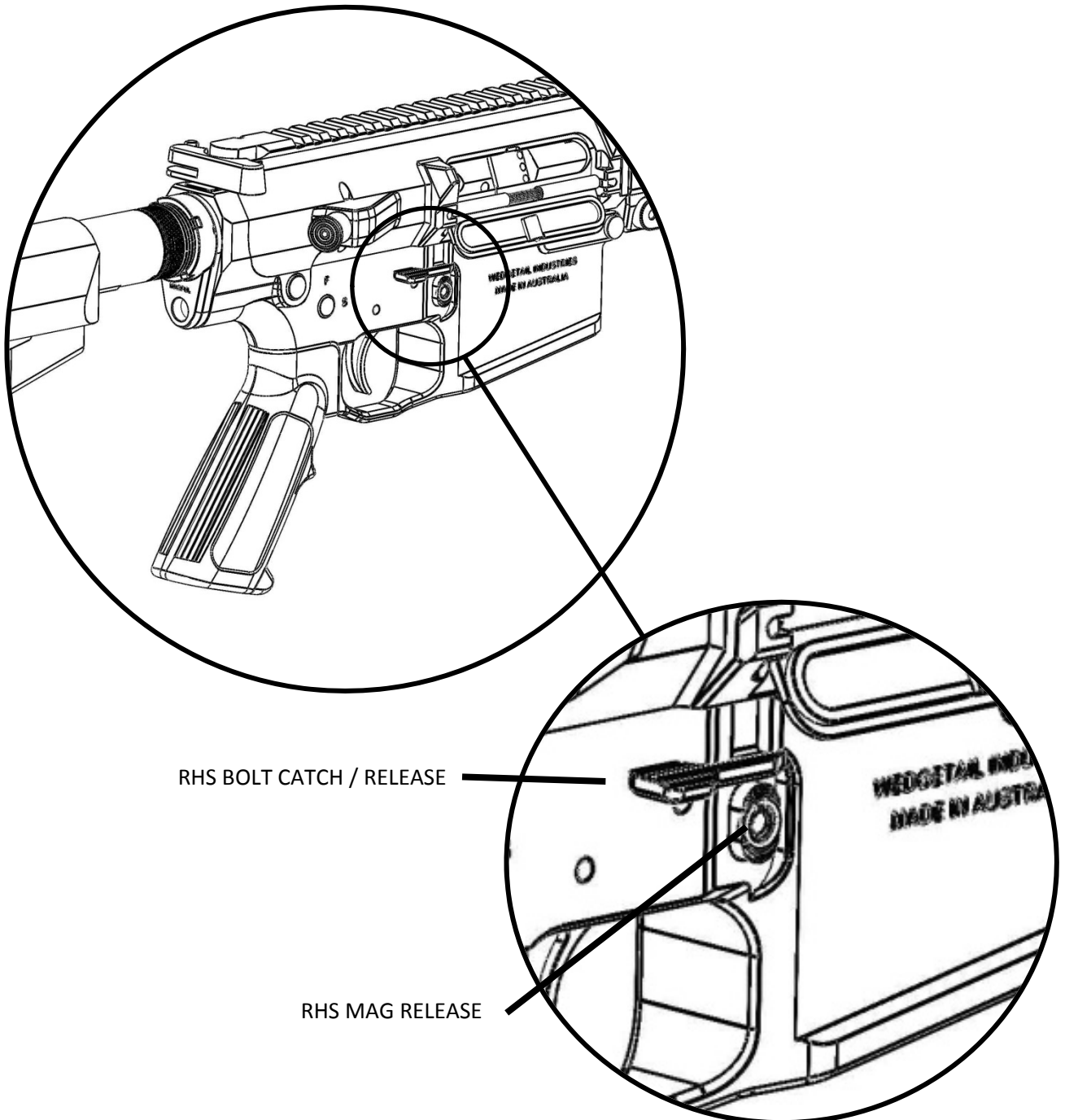

Right hand side mag release and bolt catch / release

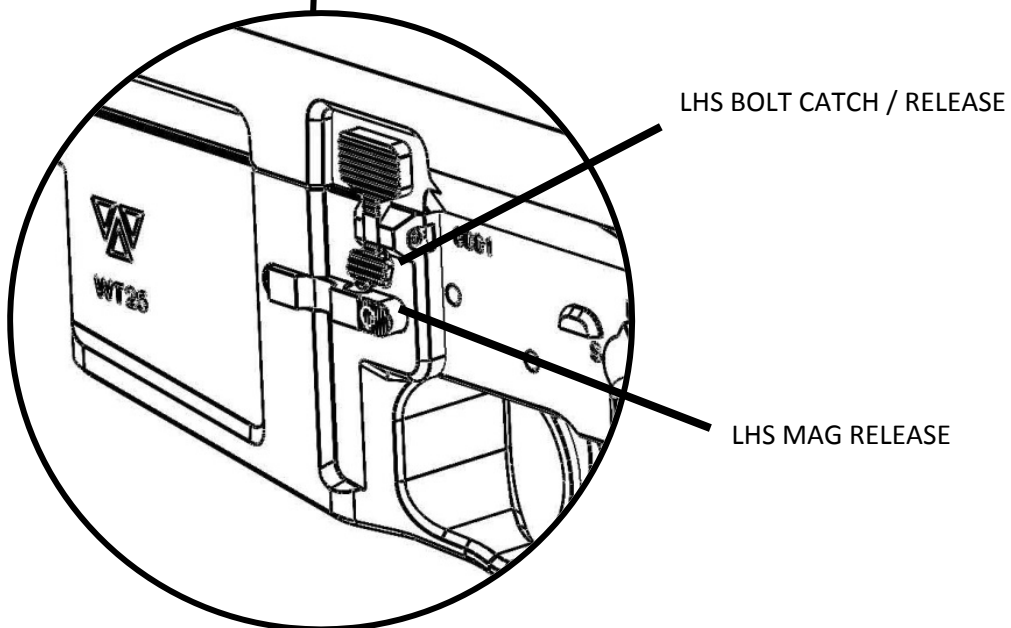
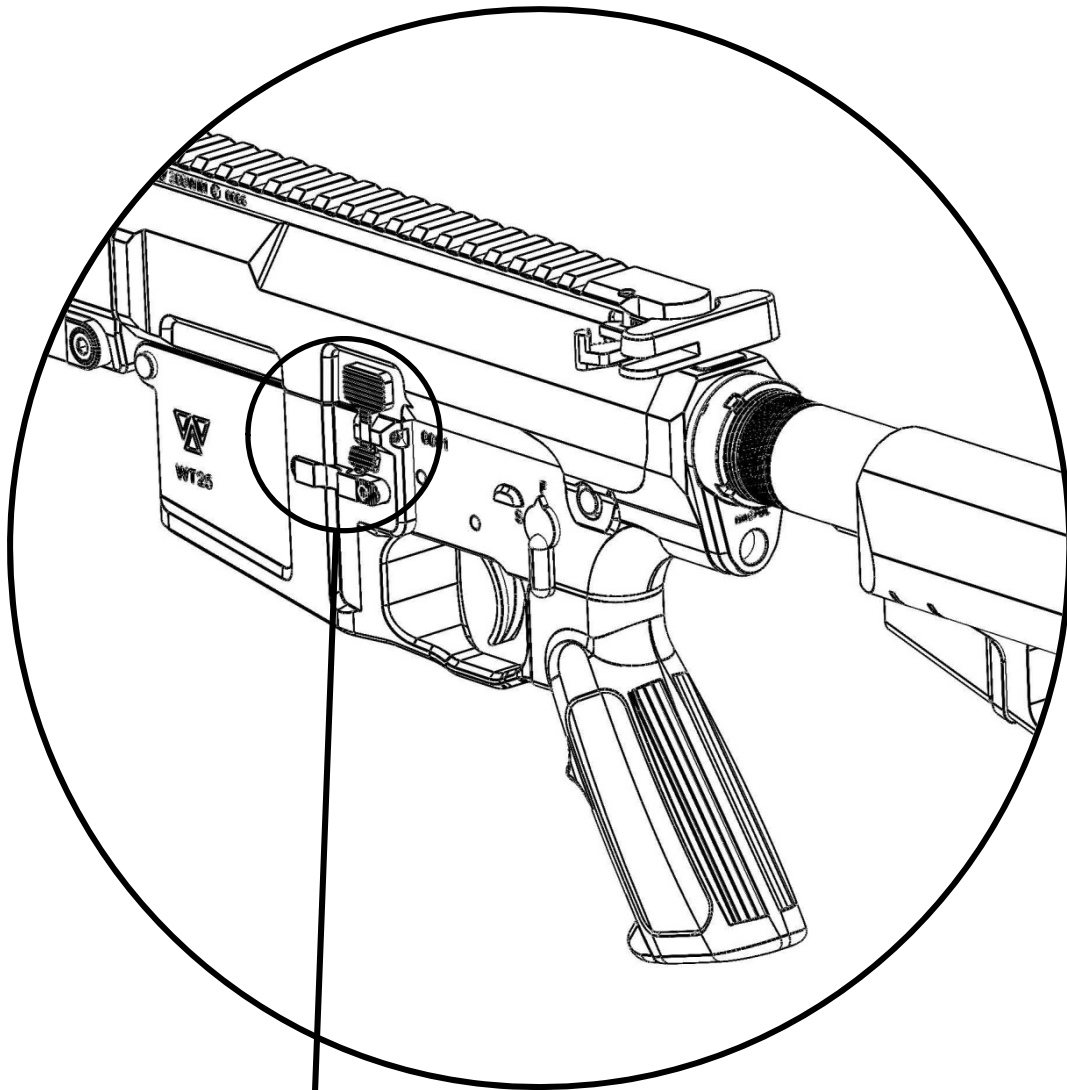

Left hand side mag release and bolt catch / release

To apply the bolt catch from the RIGHT side:

1. Use the charging handle to draw the bolt rearward against the spring as far as it will go.
2. Push in on the lower part of the bolt catch.
3. Keeping the bolt catch pushed in, slowly let the charging handle forwards. The bolt group should stop against the bolt catch.
4. Push the charging handle all the way forward until it locks into the receiver again.
5. To release the bolt, push on the upper part of the bolt catch. The bolt carrier will fly forward under spring tension. If a magazine containing cartridges is loaded into the rifle, a round will be chambered.

To apply the bolt catch from the LEFT side:

1. Use the charging handle to draw the bolt rearward against the spring as far as it will go.
2. Push the left hand side of the bolt catch lever upward with your trigger finger.
3. Keeping the bolt catch pushed in, slowly let the charging handle forwards. The bolt group should stop against the bolt catch.
4. Push the charging handle all the way forward until it locks into the receiver again.
5. Using your trigger finger again, pull down on the lever on the left hand side of the receiver. The bolt carrier will fly forward under spring tension. If a magazine containing cartridges is loaded into the rifle, a round will be chambered.

Magazine release (17)

The magazine release holds the magazine into the rifle. The magazine release is automatically applied when a magazine is inserted into the magazine well. The magazine release can be activated from either side of the rifle.

To activate the magazine release from the LEFT side:

- 1) Use the right thumb, or left index finger, to push in on the button at the rear of the magazine release.
- 2) The magazine will fall out of the magazine well. If you want to retain the magazine, hold onto the magazine before you push the magazine release button.

To activate the magazine release from the RIGHT side:

- 1) Use the right index finger, or left thumb, to push in on the button.
- 2) The magazine will fall out of the magazine well. If you want to retain the magazine, hold onto the magazine before you push the magazine release button.

4.6 CHANGING BETWEEN OPERATING CONDITIONS ON THE WT25

Once you have familiarised yourself with the controls and operation of the WT25, you are ready to practice putting the WT25 into different operating conditions (Magazine Loaded, Round in the Chamber, Ready to Fire, Unloaded).

Never cycle live ammunition through the rifle anywhere except at a firing range or another safe place to fire the WT25 rifle. Never cycle live ammunition in a residential area, dwelling, or any other area where you would not want to fire a firearm. If you want to practice loading cartridges with the WT25, purchase inert, non-firing 'drill rounds' for this purpose.

4.7 CLEARING THE RIFLE

The most important step whenever you handle a firearm is to check to make sure the firearm does not contain any ammunition in either the chamber or the magazine. To clear the WT25, use the following procedure:

- 1) Keeping the rifle pointed in a safe direction and with your finger clear of the trigger, hold the rifle by the pistol grip using your master hand.
- 2) Observe the safety catch. If the safety catch is on 'F' – Fire, rotate the safety catch counter-clockwise so it is pointing at 'S'- Safe. The firing catch will only go to safe if the rifle hammer is cocked. If the firing catch will not go to safe, the rifle hammer is not cocked.
- 3) If the magazine is fitted, remove the magazine by pushing the magazine release button.
- 4) Use the charging handle to draw the bolt all the way to the rear.
- 5) With the bolt held back, apply the bolt catch.
- 6) Slowly release the charging handle until the bolt is held by the bolt catch. Push the charging handle all the way forward.
- 7) Inspect the chamber for ammunition. If there is no ammunition in the chamber, it is safe to proceed with handling the rifle.

4.8 Magazine Loaded Condition

The 'Magazine Loaded' Condition is when there is a magazine in the rifle but no round in the chamber.

Using an empty magazine and with no ammunition present, practice putting the rifle into the 'Magazine Loaded' condition:

1. Hold the rifle's pistol grip with your master hand.
2. With your non-master hand, draw the charging handle to the rear as far as it will go.
3. While keeping the charging handle held back, apply the bolt catch from either the left hand side or right hand side of the rifle.
4. Slowly release the charging forwards until the bolt group is held in the rear position by the bolt catch.
5. Push the charging handle all the way forward into the receiver.
6. Put the safety catch to 'S'-Safe.
7. Insert an **EMPTY** magazine into the magazine well with your non-master hand. You will hear a click as the magazine catch engages on the magazine. Pull downward on the magazine to make sure it is seated.

4.9 Ready to Fire Condition

The rifle is now ready to go to 'Ready to Fire'. To go to 'Ready to Fire' condition:

1. Ensure that, for this practice, there are no rounds in the magazine by looking into the magazine well.
2. From either the left hand side or the right hand side, release the bolt catch. The bolt group will move forward very quickly under spring pressure.
3. The safety catch should still be on 'S'-Safe.

The rifle is now in 'Ready to fire' condition and can go to 'Safety off' condition.

4.10 To apply 'Safety off'

1. Rotate the safety catch to 'F' Fire.
2. Squeeze the trigger. You will hear the hammer drop, indicating that a round would have been fired.
3. Unless you are planning to fire another round immediately, apply the safety catch.

If you were shooting live rounds, you would then fire rounds until you wanted to unload the rifle – that is, to put the rifle into the 'Unloaded' condition.

4.11 To go to 'unloaded' condition

1. Check the safety to be sure it is set on **S-Safe**.
2. Remove the magazine from the rifle.
3. With your non-master hand, draw the charging handle to the rear as far as it will go.
4. The live round will be ejected from the chamber. Retain the live round.
5. While keeping the charging handle held back, apply the bolt catch from either the left hand side or right hand side of the rifle.
6. Slowly release the charging forwards until the bolt group is held in the rear position by the bolt catch.
7. Inspect the chamber to ensure there is no round in the chamber.
8. If there is no round in the chamber, release the bolt forward using the bolt catch.
9. Apply the safety selector to **F-Fire**.
10. Pull the trigger to release the hammer forwards. The Safety selector will not go to **S-Safe** as the hammer is not cocked.
11. The rifle is now in the **UNLOADED** condition.

Pre-firing inspection, cleaning, and adjusting the gas

Now that you are familiar with the operating controls and operating conditions of the WT25 rifle, you can adjust the gas settings for the rifle to suit your ammunition type. You can also sight in your rifle and practice firing the rifle.

As you should always do when picking up a rifle, first clear the rifle following the procedure in this manual. This ensures the rifle is in the **UNLOADED** condition.

5.0 FIRST FIRING OF THE WT25

5.1 CLEANING BEFORE FIRING

Once the rifle is unloaded, check to make sure the working parts are properly lubricated. Refer to the section –Care and Maintenance. It is important to make sure the working parts are properly lubricated. Using a rifle that is not properly lubricated will cause malfunctions and excessive wear on the rifle's working parts.

It is also very important to check the barrel for obstructions and pull the barrel through with a clean swab or mop to remove excess oil. When the rifle was shipped, the bore was given a coat of protective oil. Firing the rifle without removing this oil will cause higher than normal pressures in the bore of the weapon as the bullet tries to force past the oil layer.

To remove the oil from the bore:

1. Lock the bolt of the rifle back.
2. Take the cleaning kit that was supplied with the rifle. Apply a clean patch to the flexible cleaning pull-through.
3. Push the non-patch brass end of the flexible cleaning pull-through into the chamber of the rifle.
4. Feed the flexible pull-through all the way down the bore until the brass end comes out of the muzzle. If your rifle is equipped with a muzzle brake, you may need to use a bullet tip or other tool to guide the brass end away from the muzzle brake slots.

5. Pull the pull-through all the way through and out of the muzzle. You will observe a small amount of oil on the cleaning patch.

Now that the rifle is ready to be fired, you can practice loading the magazine and adjust the gas setting for the particular ammunition you want to use with the rifle.

5.2 LOADING THE MAGAZINE

To load cartridges into the magazine, follow the procedure below



- 1 Hold the magazine firmly in the non-master hand, resting the base of the magazine of the magazine on a flat surface.
- 2 Note the front and rear of the magazine. The magazine has an engraving of a cartridge marked 7.62x51 on each side of the magazine, below the feed lips. This indicates which way round the cartridges face.
- 3 Pick up a cartridge with the master hand. Check that the cartridge is the correct type and is not excessively dirty, corroded, deformed or otherwise in poor condition.
- 4 With the cartridge facing bullet forwards, align the cartridge with the back wall of the magazine.

- 5 Press the cartridge downward into the magazine, between the feed lips. The cartridge will snap into position.
- 6 Make sure the cartridge is pushed up against the rear wall of the magazine.
- 7 To adjust the gas correctly, you only need one round in the magazine.
- 8 To fully load the magazine, repeat the above until the magazine is full. The magazine should hold 20 cartridges. When the last round is loaded, it should still be possible to press the last round downward approximately 5mm further into the magazine.
- 9 If the last round is very tight and won't move downward, remove it. It will be difficult to chamber and may cause a malfunction. You may get better function with 19 rounds in some magazines.

5.3 ADJUSTING THE GAS SETTING FOR DIFFERENT AMMUNITION

Why the gas setting needs to be adjusted

Your rifle's gas block has been adjusted at the factory for optimal function with our test ammunition, which is .308 Winchester 130g American Eagle Hollowpoint.

However, your ammunition may be different and may generate different amounts of gas to work properly. If you use a suppressor you will also need to adjust the gas block settings.

If the gas block is set too low, there will not be enough gas pressure going through the system. The bolt carrier will not come back far enough and the rifle will not cycle properly. Fired cases may not be extracted or ejected from the chamber. Or cases may eject, but the bolt will not come back far enough to pick up a new round from the magazine.

If the gas block is set too high, there will be too much gas pressure going through the system. Too much gas pressure will cause excessive recoil. The bolt carrier will bounce off the rear of the buffer tube and close too quickly. This may cause the bolt to close on an empty chamber, as the magazine will not be able to feed a new round into position quickly enough. If the bolt carrier is cycling too quickly, it may also trap the empty case in the receiver before the empty case can clear the receiver.

Note: Avoid firing with the gas setting set to 'fully off'.

It is not recommended to fire the rifle with the gas set to 'fully off'. The rifle relies on gas pressure to assist in opening the bolt. If you fire the rifle with the gas set to 'fully off', it may be difficult to manually extract the case from the chamber. To avoid this, always have the gas set to at least partly open.

5.4 How to adjust the rifle gas setting

The gas block is located under the handguard. Make sure the rifle is unloaded before adjusting the gas setting.

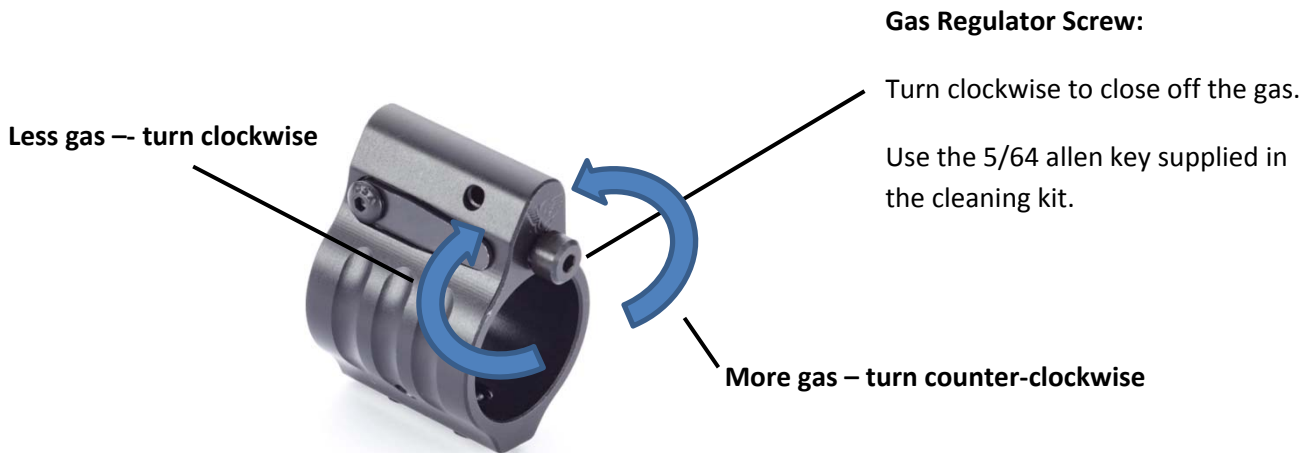

The adjustments must be done in a safe area following all safety rules. “Make sure that the rifle is unloaded, the bolt is locked back, and there is no ammunition in the chamber. Never stand in front of the muzzle when adjusting the gas.

1. The gas block is located under the handguard above the barrel.
2. The gas is adjusted by turning the gas regulator screw in the front of the block. When the gas screw is in as far as it will go, the gas is set to ‘no gas’ or fully closed. If the gas screw will not screw in, remove it from the gas block by unscrewing the screw all the way out. Apply some oil into the hole, wait for the oil to soak in, then re-install.
3. The gas regulator screw has 15 positions. Each position is indicated by a click. At 15 clicks from closed, the gas is set to ‘fully open’. The gas regulator screw can be removed from the gas block by simply unscrewing it all the way out. It is recommended that the gas screw be removed and cleaned as part of the cleaning process.
4. Use a 5/64 allen key to adjust the screw. There is an allen key in the cleaning kit supplied with the rifle.
5. Turn the regulator on the front of the gas block in a clockwise direction until it stops (do not over tighten). This will fully restrict the gas going to the gas tube.
6. In order to adjust this gas block, all you need to do is rotate the regulator in an anti-clockwise direction to the correct position for your ammunition. The built-in spring-loaded detent ensures the retention of each of the 15 adjustment positions and provides audible clicks making it easier to know in which position you are by counting the clicks
7. Rotate the regulator 8 clicks to the halfway position.

8. Load one round into the magazine.
9. Chamber and fire one round. The round should fire and lock the bolt back. If there is not enough gas to properly extract, eject the fired case and lock the bolt back further adjustment is needed
10. Now turn the adjustment regulator 2 more clicks. Fire the rifle again with 1 round in the magazine. Continue this until the bolt locks open. Once it locks back this is the point where you have enough pressure to function the rifle.
11. Now test the rifle with a fully loaded magazine. Make sure it ejects and functions correctly and locks the bolt when empty. You can rotate the gas regulator another one or two clicks to make sure the rifle will still function when it is excessively dry or dirty.

Once the procedure above has been completed, the rifle is ready to sight in and shoot. As you use the rifle more, it will become smoother as all the parts wear in. There will be less friction in the moving parts. As a result, the rifle will need less gas to function. You may be able to turn the gas down after you have fired several hundred rounds.

5.5 Adjusting the gas setting for storage

It is recommended whenever the rifle is cleaned to turn the adjustment screw to the fully closed position before any bore cleaners are used. Count how many clicks it takes to go to 'fully closed' so you can return to the right position.

When finished, return the screw to your favoured shooting position. This will also break free any carbon build-up that may occur inside the gas regulator.

6.0 TROUBLESHOOTING

6.1 IDEAL EJECTION PATTERN

The direction that fired shells go in gives an idea of whether the gas is correctly adjusted, or is too high, or too low.

Adjust the gas block regulator until your fired cases are ejecting in accordance with the diagram below.

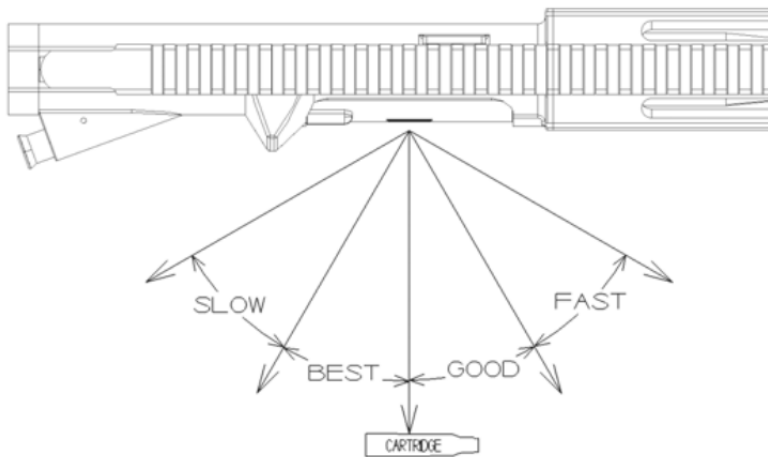

6.2 CLEARING STOPPAGES AND MALFUNCTIONS

The most common malfunction will be either a mis-fed round or an empty case stuck in the receiver. To clear either of these malfunctions, carry out the following:

1. Use the charging handle to bring the bolt all the way to the rear
2. Apply the bolt catch to keep the bolt to the rear
3. Remove the magazine
4. Remove the live round or fired case
5. Re-insert the magazine
6. Release the bolt catch to send the bolt forward and chamber a new round
7. Carry on firing.

	<p>Warning: Ammunition that has been involved in a stoppage must be removed from use and must never be replaced in the magazine. Ammunition must not be used as a tool during stoppages. These rules apply whether the ammunition appears to be damaged or not.</p>
---	--

7.0 MAINTENANCE:

Other than disassembly as described for cleaning, any maintenance should only be carried out by the Wedgetail Industries approved armourer or by a suitably qualified gunsmith.

7.1 FIELD STRIPPING AND DISASSEMBLY:

Prior to any disassembly, ensure your rifle is at the 'UNLOAD' condition by carrying out the unloading and rifle clearing steps as described earlier in this manual. Follow the sequence of steps as listed below to 'Field Strip' your rifle.

Do not strip your rifle down any further than specified in these instructions. Detailed stripping of the subassemblies should only be conducted at the Wedgetail Industries factory or by a suitably trained and accredited gunsmith. Ensure you conduct any disassembly work in a clean area when at home or on a clean mat in the field. Make sure the area is clear of tools, parts, or other objects that might damage the finish on the rifle.

7.2 To field strip upper and lower assembly

- 1** Cock the rifle by grasping the charging handle and bringing the bolt group all the way to the rear.
- 2** Release the bolt group forward. Set the safety selector lever to 'S' safe position.
- 3** Disengage the rear take down pin by pushing it in, from left to right. If the pin is tight, use a soft, non-marking drift or wooden dowel and a soft faced hammer to get it started.
- 4** The upper and lower receiver assemblies will then rotate apart around the front take down pin.
- 5** Remove the bolt carrier assembly by pulling back on the charging handle. The charging handle will stop when it lines up with the charging handle clearance grooves in the receiver.
- 6** Pull the bolt carrier group up and out of the rifle.
- 7** Remove the charging handle by pulling it out rearwards, until the lugs on the charging handle line up with the keyed slots into the upper receiver charging handle track. Pull the charging handle up and out of the track and remove it from the upper receiver;

- 8 Disengage the front take down pin by pushing it from left to right. The upper and lower receivers can now be separated. No further take down / stripping down action is required for the upper receiver and barrel assembly.
- 9 Take up the lower receiver and stock assembly. Place the lower receiver onto a suitable magazine insert vice block to assist with stability if available. If not, support the lower receiver and stock assembly between your knees and place your non-master thumb over the front flat surface of the buffer.
- 10 Apply a small amount of pressure to the buffer and push it back down the tube approximately 3mm.
- 11 Using a small pin punch, press down the buffer retaining plunger and slowly and under control release the pressure on your left thumb, allowing the buffer and buffer spring to come out of the buffer tube under control.
- 12 Failure to properly restrain the buffer whilst depressing the buffer retaining plunger can result in injury and loss of parts. Do not unscrew the castle nut or unscrew the buffer tube from the lower receiver.

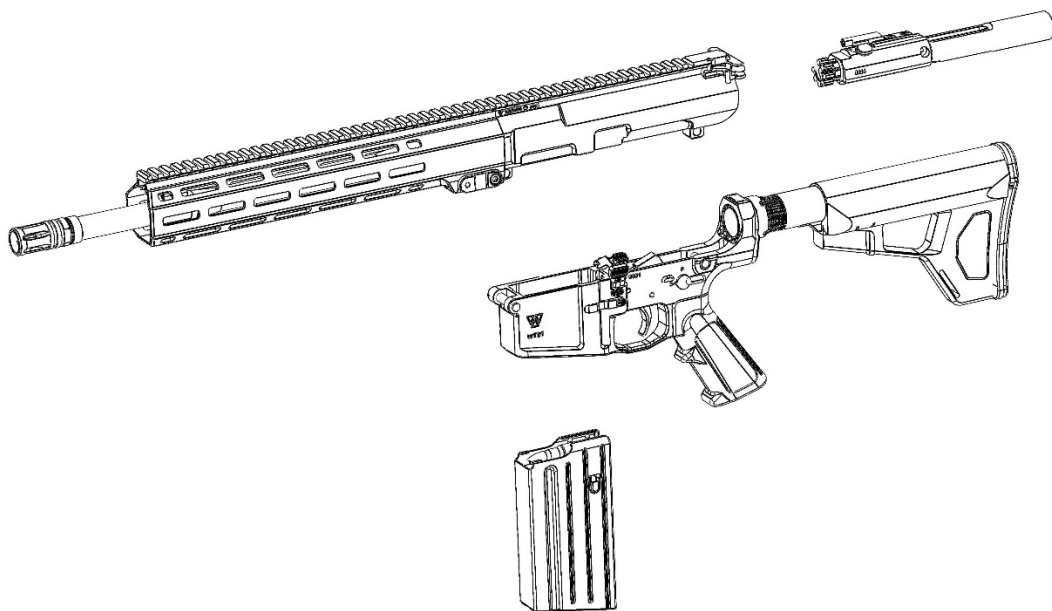

Rifle Sub-Assemblies

7.3 To Field Strip the bolt carrier group

- 1 Remove the bolt carrier weight from the bolt carrier by pushing it out. It is secured by an O-ring so there will be some friction.
- 2 Remove the firing pin retaining pin from the bolt carrier by pushing it out from right to left.
- 3 Tilt the bolt carrier so the firing pin falls out of the rear of the bolt carrier.
- 4 Push the bolt in so the cam pin rotates to the rear.
- 5 Pull the cam pin out of the bolt.
- 6 Remove the bolt assembly by pulling it forward and out of the bolt carrier.

The bolt carrier is now stripped.

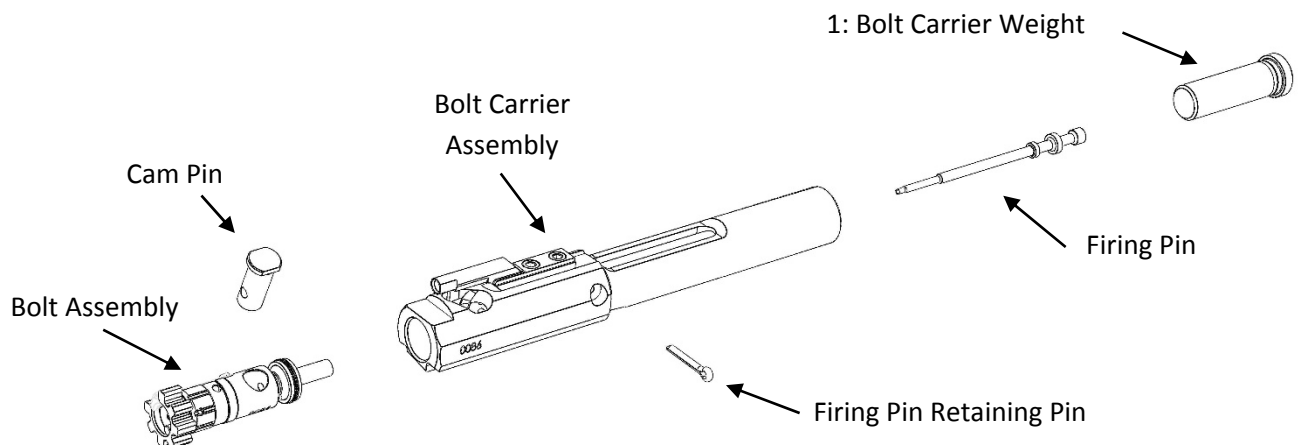



Figure 10: Field Stripped Bolt Carrier Group

NOTE: AT NO STAGE SHOULD AN OWNER ATTEMPT TO DISASSEMBLY THE RIFLE BEYOND THE SUB-ASSEMBLIES

	<p>Warning: do not attempt to strip the bolt or bolt carrier down any further than as described above. Damage or loss of parts may occur. Detailed stripping of the subassemblies should only be conducted by Wedgetail Industries or by a suitably trained and accredited gunsmith.</p>
---	---

7.4 To reassemble the bolt carrier group

- 1.** Push the bolt into the bolt carrier. Note that the cam pin hole in the bolt does not go all the way through the bolt. This means the cam pin can only be inserted into the bolt from one side. This feature prevents the bolt from being incorrectly re-assembled.
- 2.** The gas rings on the bolt will make the bolt slightly tight to insert into the carrier.
- 3.** Line up the bolt cam pin hole with the bolt carrier cam pin track, at the rear of the cam pin track.
- 4.** Insert the cam pin through the cam pin track in the bolt carrier and into the cam pin hole in the bolt. Make sure the firing pin hole in the cam pin is in line with the bolt carrier – that is, so the firing pin can go through the firing pin hole in the cam pin.
- 5.** Pull the bolt forward so that the cam pin rotates and is in the fully forward position.
- 6.** Hold the bolt carrier vertically so the bolt is facing down. Drop the firing pin into the bolt so that it goes all the way into the bolt as far as it can.
- 7.** Insert the firing pin retaining pin all the way into the bolt carrier.
- 8.** Replace the bolt carrier weight into the rear of the bolt carrier
- 9.** Move the bolt in and out of the carrier to ensure it moves freely.
- 10.** Push the bolt all the way into the carrier. Make sure the tip of the firing pin protrudes slightly from the bolt face when you press on the firing pin. If it does not, remove the firing pin and reinstall.
- 11.** Pull the bolt all the way forward so the cam pin is as far forward as it will go.
- 12.** The bolt carrier is now ready to insert into the rifle.

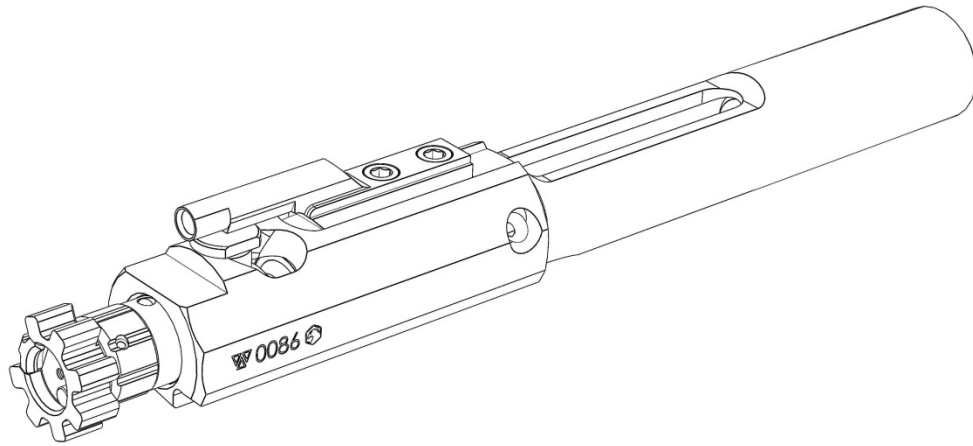

Bolt open – cam pin in the forward position, ready to be inserted into the rifle

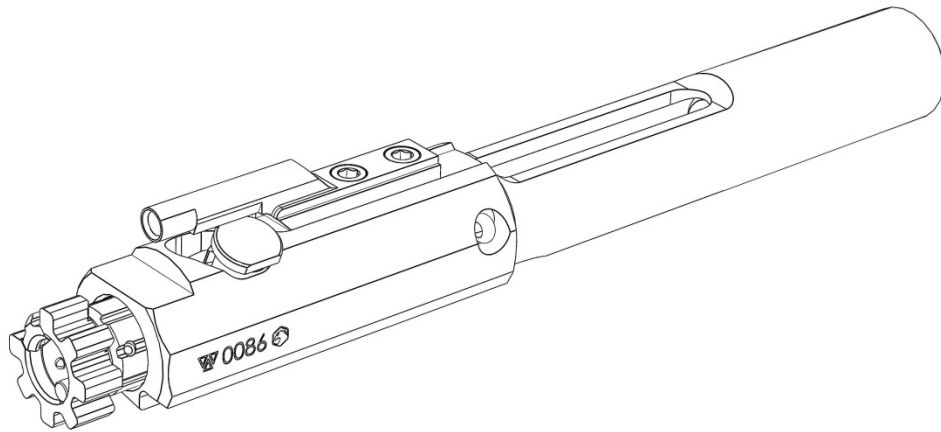

Bolt closed – cam pin in the rearward position

8.0 CLEANING AND ENVIRONMENTAL CARE INSTRUCTIONS:

Use the cleaning kit provided with the WT25 rifle. Refer to the separate instructions contained in the cleaning kit for the use of the cleaning kit.

8.1 To clean the Upper Receiver Group and barrel

The barrel is to be cleaned as follows:

1. Exterior: The exterior of the barrel can be cleaned using the double-ended bristle brush provided and lightly oiled by wiping over with a lightly oiled piece of flannelette. Clean the exterior of the barrel, paying particular attention to the grooves in the flash hider and the rail interface system. **CAUTION** Do not use wire brushes on aluminium surfaces.
2. Interior: Clean using a cloth or flannelette ensuring that the charging handle track is clean the internal area is free of dirt or debris.
3. Gas block. Clean the exterior of the gas tube which protrudes into the upper receiver. **CAUTION** Do not use any abrasive material to clean the gas system.
4. Chamber. The chamber is cleaned using the chamber brush attached to the cleaning rod and wiped dry using a piece of flannelette; and
5. Bore. ***Prior to cleaning the bore the gas block must be closed (see 8.0)*** To clean the bore: Any fouling of the bore can be removed by using the wire bore brush dipped in CLP (or similar). To do this, attach the bore brush to the assembled length of cleaning rod (minus handle), drop the rod through the barrel from the chamber end, then attach the cleaning rod handle (if required) and pull through in a smooth motion.
6. Once this is completed, repeat using flannelette or a mop brush attachment.

8.2 To clean the Lower Receiver

Clean the lower receiver group as follows:

1. Clean the external surfaces using flannelette or cloth and a bristle brush provided;
2. Clean the trigger mechanism and all internal components with flannelette and / or cotton que tips, ensuring that it is free of dirt and debris; and dry and lightly oil – do not oil polymer surfaces.

8.3 To clean the Buffer Assembly

Buffer Assembly. The buffer assembly is to be cleaned as set out as follows:

1. Wipe all oil residue from inside the buffer receiver using flannelette.
2. Clean the action spring guide and lightly oil. White Lithium Grease is recommended.
3. Remove all oil residue from the action spring, lightly oil / grease.

8.4 To clean the Bolt and Carrier Group

Bolt Group. The bolt group is to be cleaned as follows:

1. Wipe all oil residue from inside the bolt carrier (use a rod section and flannelette), bolt key, bolt and firing pin. The bolt face is to be left clean and free from oil. Use a bristle brush to clean the bolt face and locking lugs.
2. The body of the bolt carrier can be wiped over with a lightly oiled piece of flannelette;
3. Clean the interior of the gas key using flannelette and a small rod or a cotton que tip. Dry and lubricate with one drop of oil.
4. Assemble the bolt group.

5. To lubricate the bolt carrier, press the bolt head in and apply one drop of oil to the front of the cam and one drop to the rear of the cam.
6. Dry and lightly oil all surfaces. Lubricants such as “Frog Lube” can also be used.

8.5 Reassembly

Reassemble you rifle in reverse order to the described disassembly procedure.

8.6 TEST AFTER REASSEMBLY

Once the rifle has been reassembled, it is important to check that it functions correctly and that all parts function as they should. The following procedure is to be used to test a rifle after assembly:

- 1 Checking Safety: Pull the cocking handle to the rear and release it, set the safety selector lever on ‘SAFE’.
- 2 Squeeze the trigger and you should hear no sound, as the hammer should not fall.
- 3 Release the trigger and then set the safety selector lever to ‘FIRE’;
- 4 Squeeze and keep the trigger depressed. A loud click should be heard as the hammer falls;
- 5 Pull the cocking handle to the rear and release it while keeping the trigger depressed. The hammer should not fall but be held by the disconnecter;
- 6 Release the trigger. A dull click should be heard as the hammer is released from the disconnecter and drops part way to engage with the trigger sear; and
- 7 Pull the trigger to fire the action. After the trigger the safety selector lever should not be able to m=be moved to the ‘SAFE’ position.

8.7 ROUTINE OPERATOR'S MAINTENANCE

Perform routine maintenance after each firing session or once daily while operating in normal field conditions. Ensure rifle is clear prior to performing any maintenance. When cleaning the bore always pass the cleaning rod through the chamber end towards the muzzle. Otherwise the muzzle may be damaged and degrade accuracy.

1. Field-strip the rifle as detailed.
2. Clean bore by punching first with a patch saturated in Simple Green, SLIP 2000 Carbon Killer or approved solvent. Punch bore with bore brush several times. Punch with a dry patch to remove carbon residue and cleaning solvent.

NOTE: If you see degradation in accuracy clean bore using a copper solvent per solvent manufacturer's instructions.

Check for cleanliness by punching with a clean patch. If the patch does not come out clean, repeat steps 6.42 until it does.

3. Wipe Bolt Carrier, Charging Handle, interior of Upper Receiver, Buffer and Buffer Spring with a cloth (slightly dampened with cleaning solvent if available).
4. Scrub the face of the bolt with a GP brush dipped in cleaning solvent or CLP. Thoroughly wipe away any remaining cleaning solvent or CLP with a rag.
5. Apply a light coat of lubricant to all contact surfaces as shown below:

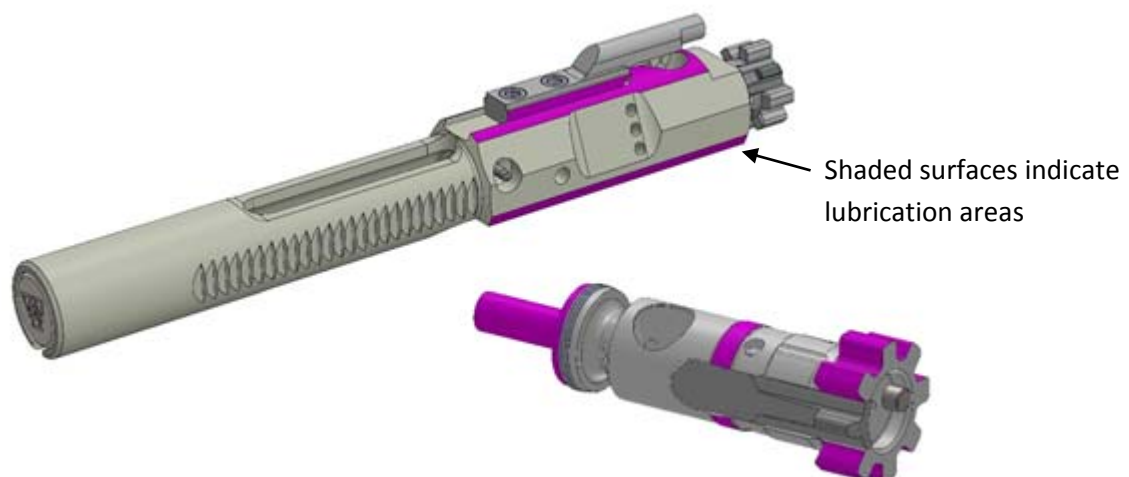

Additional lubrication points are as follows:

- Lightly lube the bearing surface of the charging handle.
- Upper receiver bore
- Hammer contact points with bolt carrier and sear
- Hammer and trigger pivot pins

9.0 USING THE WT25 IN EXTREME ENVIRONMENTS

9.1 Tropical or Wet Conditions

In tropical or wet conditions inspect and carry out normal daily cleaning on a more frequent basis. Extra applications of oil may be required on the external steel components. The safety catch should be manipulated and oiled daily to prevent sticking.

9.2 Heavy Rain

In heavy rain, inspect and carry out normal daily cleaning on a more frequent basis. If water is allowed to accumulate in the bore of the rifle, a bulged barrel or breech explosion may occur when firing. To prevent this carry the rifle with the muzzle facing down.

9.3 Dry, Sandy or Dusty Conditions

During dry, sandy or dusty conditions clean as for normal daily cleaning but keep the exterior of the rifle oil free. A light coating of graphite powder can be used as a lubricant on the working parts and trigger mechanism in extreme conditions.

9.4 Salt Water Immersion and Spray

If the rifle is affected by salt water immersion or spray, the muzzle is to be pointed down and the rifle cocked (this will ensure all water is cleared from the barrel and there is no chance of a hydrostatic lock).

As soon as practicable when ashore, strip the rifle and wash thoroughly in fresh water, then dry. Carry out normal daily cleaning and additional cleaning. Additional applications of oil may be required on external components to prevent rust. If continual exposure to salt water is experienced, a light coating of grease may be required on the external components.

10.0 SUPPRESSOR USE

When shooting with a silencer or suppressor, it is important to go through the gas adjustment procedure again with the suppressor mounted securely to the rifle.

This is because shooting with a suppressor may increase the gas back-pressure in the rifle and affect the cycling of the rifle.

The suppressor may also increase combustion gasses exiting the rifle through the rifle chamber. It is particularly important to wear PPE including safety glasses when using the rifle suppressed. It is also particularly important to only shoot the WT25 in a well-ventilated area when shooting the rifle suppressed.

Please observe the following when shooting the WT25 suppressed;

1. Follow Manufacturer's instructions for mounting/ dismounting suppressor, for care and use.
2. Use suppressor design with same calibre as the rifle.
3. Ensure suppressor is firmly attached prior to use and check its tightness regularly.
4. Cyclic rate may be increased with a suppressor due to back pressure.
5. Gas/fouling may be increased with a suppressor.
6. Rifle shall require an increase in lubrication and cleaning.
7. Utilise the adjustable gas block to reduce the amount of gas required to cycle the rifle.
8. The suppressor will get very hot during firing. Be sure to let the suppressor cool before touching the suppressor or storing the rifle in a bag or case.

11.0 TROUBLE SHOOTING

MALFUNCTION	TEST OR INSPECTION	CORRECTIVE ACTION
Double feed	Dirty magazine	Clean magazine
Round will not chamber	Dirty or corroded ammunition	Clean or replace ammunition
	Damaged ammunition	Replace ammunition
	Carbon in chamber	Clean chamber
Bolt will not close	Dirt, corrosion, or carbon in barrel or bolt locking lugs	Clean bolt locking lugs
Bolt will not extract round	Frozen extractor	Remove bolt and clean extractor
	Restricted buffer assembly	Clean buffer and spring
	Restricted movement of bolt carrier group	Remove, clean, and lubricate bolt
	Fired case stuck in chamber	Reduce gas pressure
	Dirty chamber	Clean chamber
	Cartridge stuck	Push cartridge out with cleaning rod
Short recoil	Low gas pressure	Adjust the gas regulator
Bolt fails to lock after last round fired	Low or excessive gas pressure	Adjust the gas regulator, fully close it and open 1 rotation at a time until lock open achieved
	Faulty magazine	Replace the magazine
Selector lever binds	Dirty selector lever	Check, clean and lubricate
Bolt carrier hung up	Round caught between the bolt and the upper receiver	Remove magazine, remove loose ammunition

12.0 WARRANTY INFORMATION

Wedgetail Industries products are warranted to be free from defective materials and workmanship for life of the original purchaser.

Wedgetail Industries obligation under this warranty shall be limited to (1) repairing or (2) Replacing any product upon inspection at Wedgetail Industries and based on its discretion

This warranty is limited and does not extend to: careless handling, abuse and misuse, unauthorized adjustments or modifications, use of improper ammunition, excessive or unreasonable use, ordinary wear & tear, rust or corrosion, and barrel obstruction.

Repairs are warranted for the duration of the original warranty and applies only to factory-built products

EXCLUSIVE REMEDY

The remedies in this section and in the warranty agreement constitute the sole and exclusive remedies of any authorized customer, as well as its successors and assigns, for any defect in the product.

DISCLAIMER

The warranty stated in this agreement is the sole and exclusive warranty pertaining to the product. Wedgetail Industries™ disclaims any warranty express or implied, including, without limitation, any warranty of merchantability or fitness for a particular purpose. In no event shall Wedgetail Industries™ be responsible for any indirect, incidental or consequential damages including, without limitations, lost profits, costs of delay, with respect to economic loss or injury to property or to third parties, whether as a result of breach of express or implied warranty, negligence or otherwise.

Prior to returning any Wedgetail Industries product for warranty work, you must receive return material authorization (RMA) from our customer service department.

Wedgetail Industries accepts no responsibility for items lost or damaged in shipping. Items that are returned and found to be out of warranty will be repaired at the customer's expense; however, no work will be performed without the customer's written authorization.

EXPORT CONTROL

User acknowledges that any technical data furnished by Wedgetail Industries in connection with this order may be subject to export control laws, including but not limited to the DECO Export Control Regulations and the International Traffic in Arms Regulations.

In this regard, User agrees that, unless it has obtained prior written consent from the Defence Export Control Office (DECO) they will not export, re-export, or trans-ship, directly or indirectly, the goods, documentation, technical assistance, or any media in which any of the foregoing is contained, or other technology provided hereunder or the direct product thereof, to any country or citizen.

13.0 CONTACT INFORMATION

Monday thru Friday: 10am thru 4pm AEST

Customer Service Department

Phone: 1300 885 123

Email: sales@wedgetailindustries.com

No part of this document may be copied, reproduced, or transmitted by any means, for any purpose without prior written permission from Wedgetail Industries

All images and text © 2022 Wedgetail Industries

Trademarks of Wedgetail Industries:

Wedgetail Industries™

Ninox™ WT25™ WT15™ MPR308™

14.0 WT25 MAINTENANCE SCHEDULE

ROUND COUNT											
PART	1-100	100	500-	1000-	2000-	3000-	4000-	5000-	6000-	7000-	10000 rounds
		500-	1000	2000	3000	4000	5000	6000	7000	8000	
Barrel Assembly	Bore should be cleaned every 800-1000 rounds										Replace@20K
Buffer Spring								Replace			Replace
Buffer Assembly	Inspect buffer face for damage										Replace@20K
Bolt	Inspect for cracks/missing lugs										Replace@20K
Ejector	Test for free movement										Replace
Ejector Springs	Compare free length to a new spring							Replace			Replace
Extractor	Inspect for wear to ejector face										Replace
Extractor Springs	Compare free length to a new spring							Replace			Replace
Gas Rings	Inspect rings for missing sections (while on the bolt)										Replace
Bolt Carrier Key and Screws	Verify screws are tight, 5.6Nm max torque										Replace
Firing Pin	Inspect tip for deformation										Replace
Firing Pin retaining pin	Verify retainer will remain in the carrier										Replace
Cam Pin	Inspect for heavy wear and cracks										Replace
Hammer Trigger Pins	Inspect for wear and cracks							Replace			Replace
Disconnecter Spring	Verify spring pushes disconnecter into resting position and disconnecter is free moving										Replace
Selector Detent	Inspect for worn firing pin tip										Replace
Bolt Catch Assembly	Inspect for wear, cracks and warpage to catch. Verify free movement in Lower receiver										Replace
Magazine Catch Spring	Compare free length to a new spring										Replace
Hammer Spring	Check primer indent for spring tension. Compare to new spring										Replace
Trigger Spring	Verify trigger reset. Compare to a new spring										Replace

15.0 PARTS LISTS AND DRAWINGS

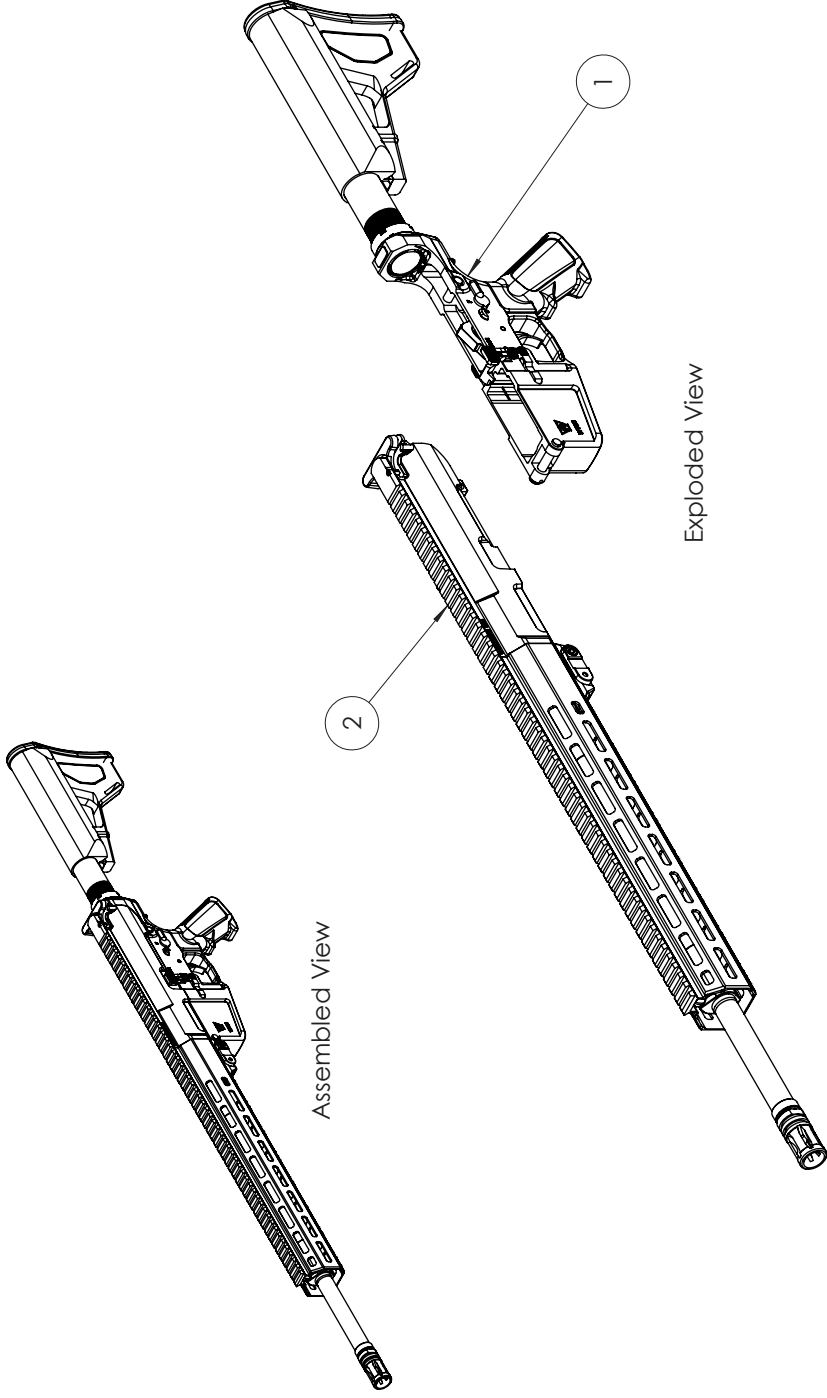

20" WT25 RIFLE

ITEM NO.	PART NUMBER	DESCRIPTION	QTY.
1	WT25-02-800	COMPLETE LOWER RECEIVER ASSEMBLY	1
2	WT25-02-801	20" 308 COMPLETE UPPER RECEIVER ASSEMBLY	1

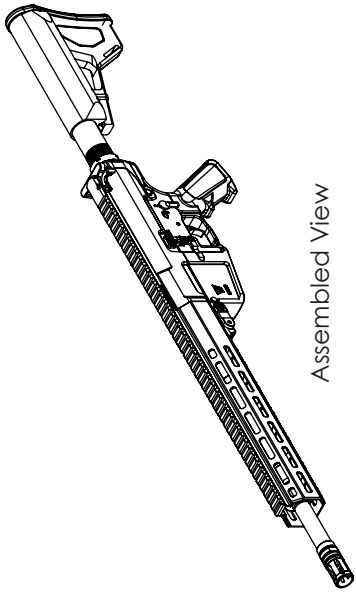

Assembled View

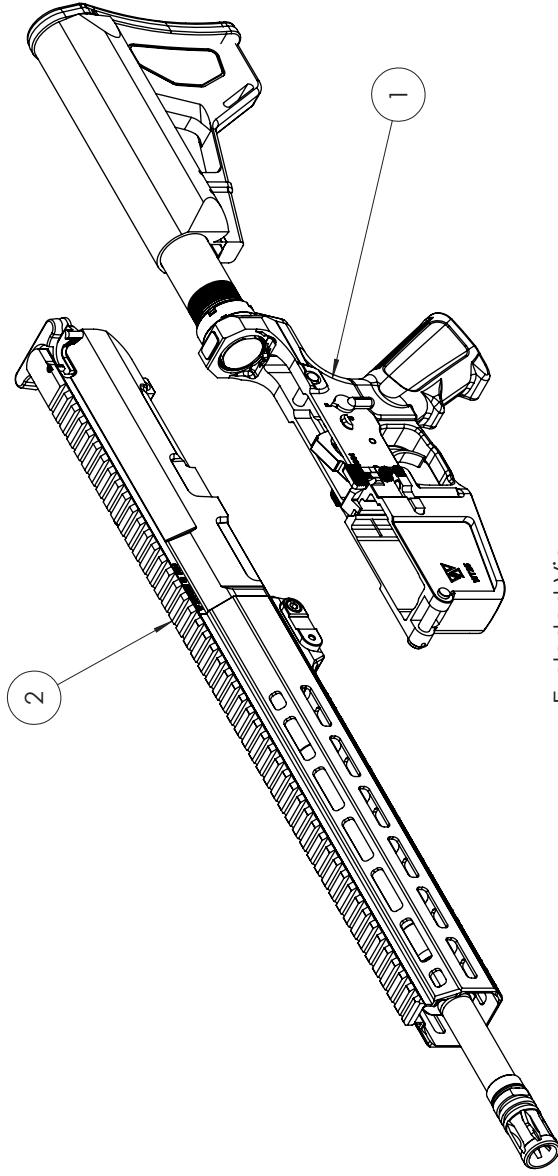

Exploded View

16" WT25 RIFLE

ITEM NO.	PART NUMBER	DESCRIPTION	QTY.
1	WT25-02-800	COMPLETE LOWER RECEIVER ASSEMBLY	1
2	WT25-02-801	20" 308 COMPLETE UPPER RECEIVER ASSEMBLY	1

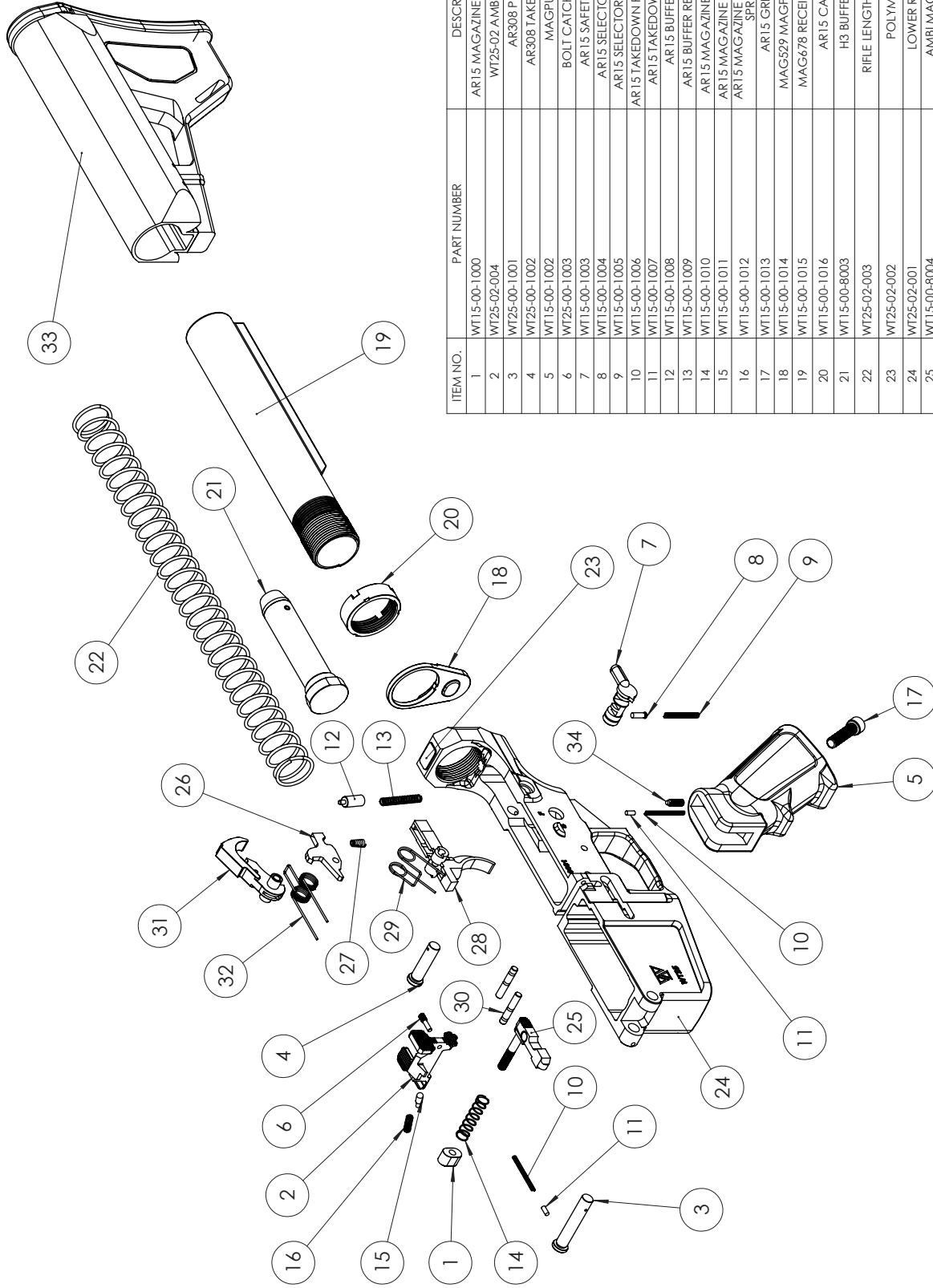

ITEM NO.	PART NUMBER	DESCRIPTION	DEFAULT/QTY.
1	WT15-00-1000	AR15 MAGAZINE RELEASE BUTTON	1
2	WT25-02-004	WT25-02 AMBI BCG CATCH	1
3	WT25-00-1001	AR308 PIVOT PIN	1
4	WT25-00-1002	AR308 TAKE DOWN PIN	1
5	WT15-00-1002	MAGPUL GRIP	1
6	WT25-00-1003	BOLT CATCH PIVOT PIN	1
7	WT15-00-1003	AR15 SAFETY SELECTOR	1
8	WT15-00-1004	AR15 SELECTOR DETENT PIN	1
9	WT15-00-1005	AR15 SELECTOR DETENT SPRING	1
10	WT15-00-1006	AR15 TAKEDOWN PIN DETENT SPRING	2
11	WT15-00-1007	AR15 TAKEDOWN PIN DETENT	2
12	WT15-00-1008	AR15 BUFFER RETAINER	1
13	WT15-00-1009	AR15 BUFFER RETAINER SPRING	1
14	WT15-00-1010	AR15 MAGAZINE CATCH SPRING	1
15	WT15-00-1011	AR15 MAGAZINE CATCH PLUNGER	1
16	WT15-00-1012	AR15 MAGAZINE CATCH PLUNGER SPRING	1
17	WT15-00-1013	AR15 GRIP SCREW	1
18	WT15-00-1014	MAG529 MAGPUL SLING PLATE	1
19	WT15-00-1015	MAG678 RECEIVER EXTENSION	1
20	WT15-00-1016	AR15 CASTLE NUT	1
21	WT15-00-8003	H3 BUFFER 5.40Z	1
22	WT25-02-003	RIFLE LENGTH SPRING 308	1
23	WT25-02-002	POLYMER TAB	1
24	WT25-02-001	LOWER RECEIVER	1
25	WT15-00-8004	AMBI MAG RELEASE	1
26	WT15-00-1017	TRIGGER DISCONNECTOR	1
27	WT15-00-1018	AR15 DISCONNECTOR SPRING	1
28	WT15-00-1019	TRIGGER LEVER	1
29	WT15-00-1020	TRIGGER LEVER SPRING	1
30	WT15-00-1021	AR15 TRIGGER PIN	2
31	WT15-00-1022	AR15 HAMMER	1
32	WT15-00-1023	AR15 HAMMER SPRING	1
33	WT25-00-8004	MAGPUL STOCK	1
34	WT25-00-1004	M4 POLYMER TIP GRUB SCREW	1

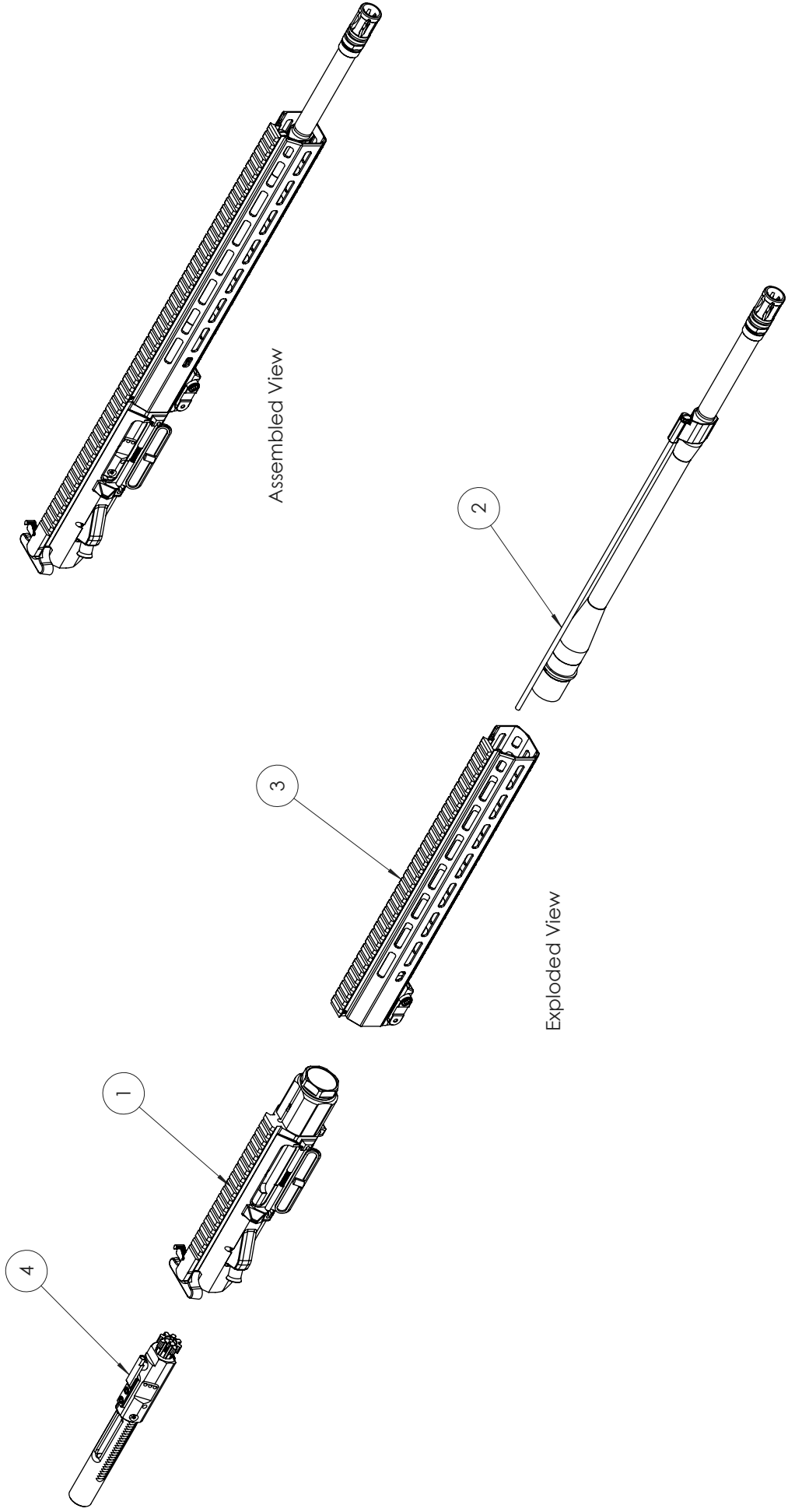

20" WT25 RIFLE

ITEM NO.	PART NUMBER	DESCRIPTION	QTY.
1	WT25-02-804	WT25 308 Upper Receiver Assembly	1
2	WT25-02-810	WT25 308 500mm Barrel Assembly	1
3	WT25-02-806	WT25-02 X Bolt Handguard 14	1
4	WT25-02-805	WT25 308 Bolt Carrier Assembly	1

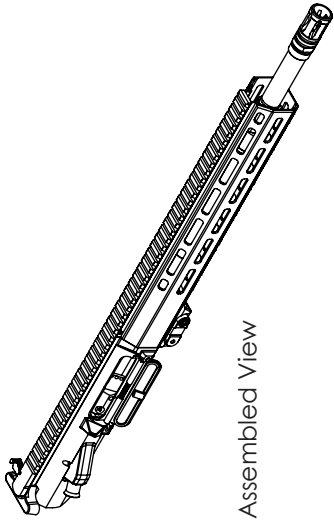

Assembled View

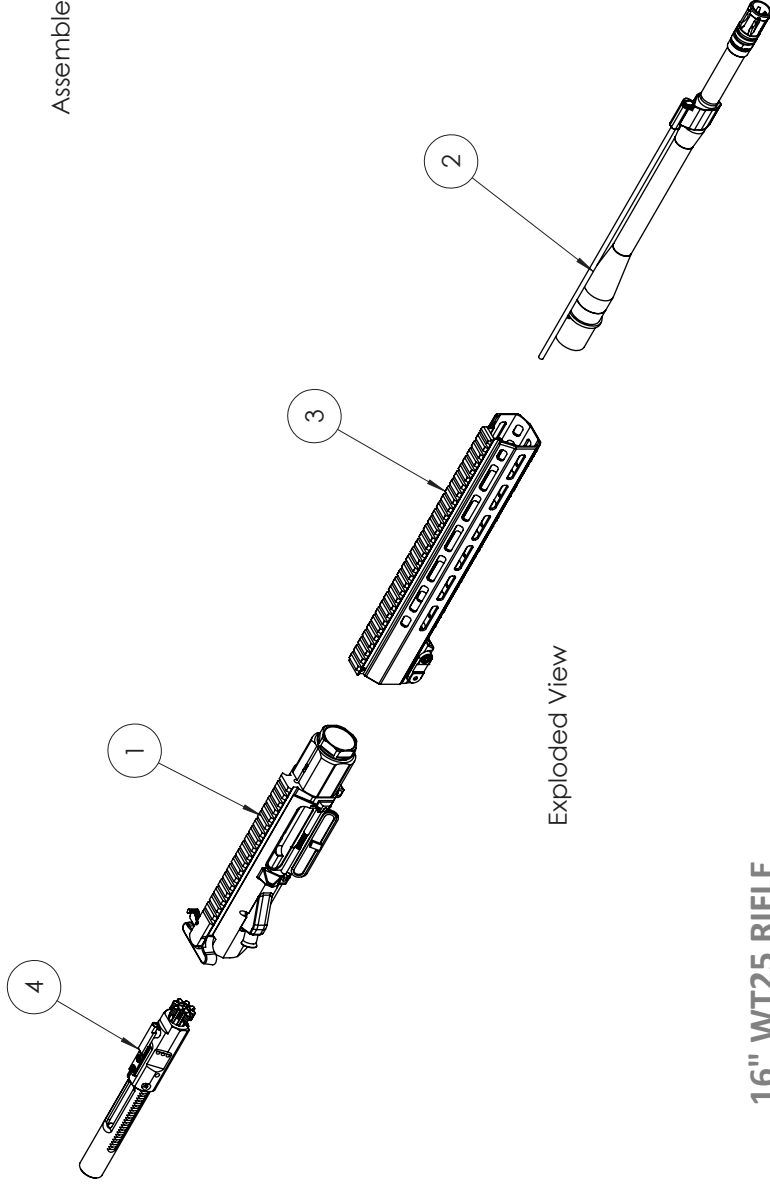

Exploded View

16" WT25 RIFLE

ITEM NO.	PART NUMBER	DESCRIPTION	QTY.
1	WT25-02-804	WT25 308 UPPER RECEIVER ASSEMBLY	1
2	WT25-02-808	WT25 308 16" BARREL AND INTERMEDIATE GAS ASSEMBLY	1
3	WT25-02-807	WT25-02 X BOLT HANDGUARD 12	1
4	WT25-02-805	WT25 308 BOLT CARRIER ASSEMBLY	1

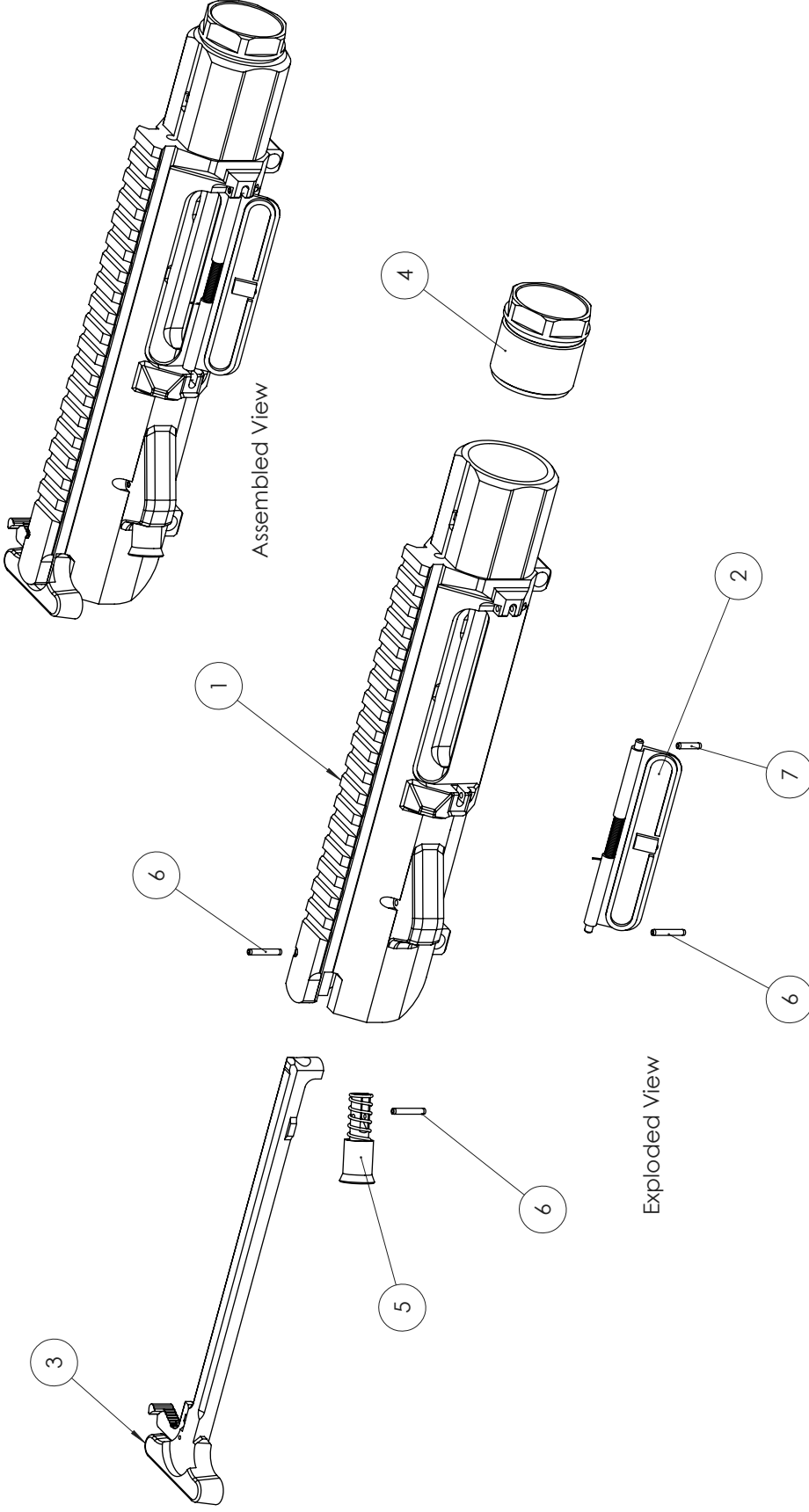

ITEM NO.	PART NUMBER	DESCRIPTION	QTY.
1	WT25-02-005	WT25 UPPER RECEIVER	1
2	WT25-00-8000	EJECTION PORT COVER	1
3	WT25-00-8001	CHARGING HANDLE	1
4	WT25-02-006	WT25 BARREL NUT	1
5	WT15-00-8002	FORWARD ASSIST ASSEMBLY	1
6	WT25-00-1000	ROLL PIN 3/32 dia x 5/8	3
7	WT25-00-1005	ROLL PIN 3/32 DIA X 7/16	1

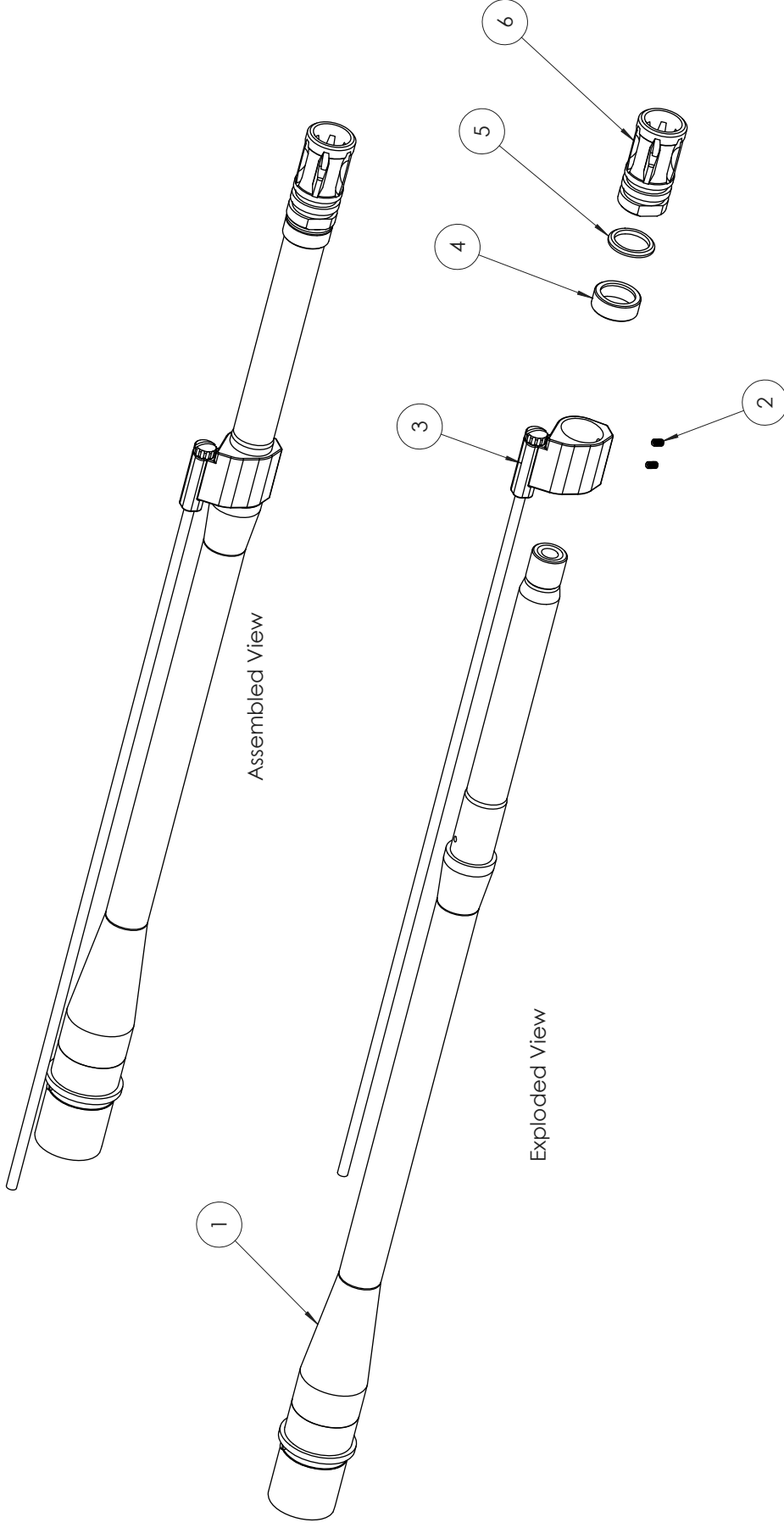

20 INCH RIFLE LENGTH BARREL ASSEMBLY

ITEM NO.	PART NUMBER	DESCRIPTION	QTY.
1	WT25-02-814	500mm BARREL ASSEMBLY	1
2	WT25-00-0019	10/32 X 3/16 SET SCREW	2
3	WT25-00-8002	ADJUSTABLE GAS BLOCK RIFLE LENGTH	1
4	WT25-02-015	TAPER SPACER 308	1
5	WT25-00-1021	CRUSH WASHER 5/8-24	1
6	WT25-00-1020	FLASH HIDER 5/8-24 THREAD	1

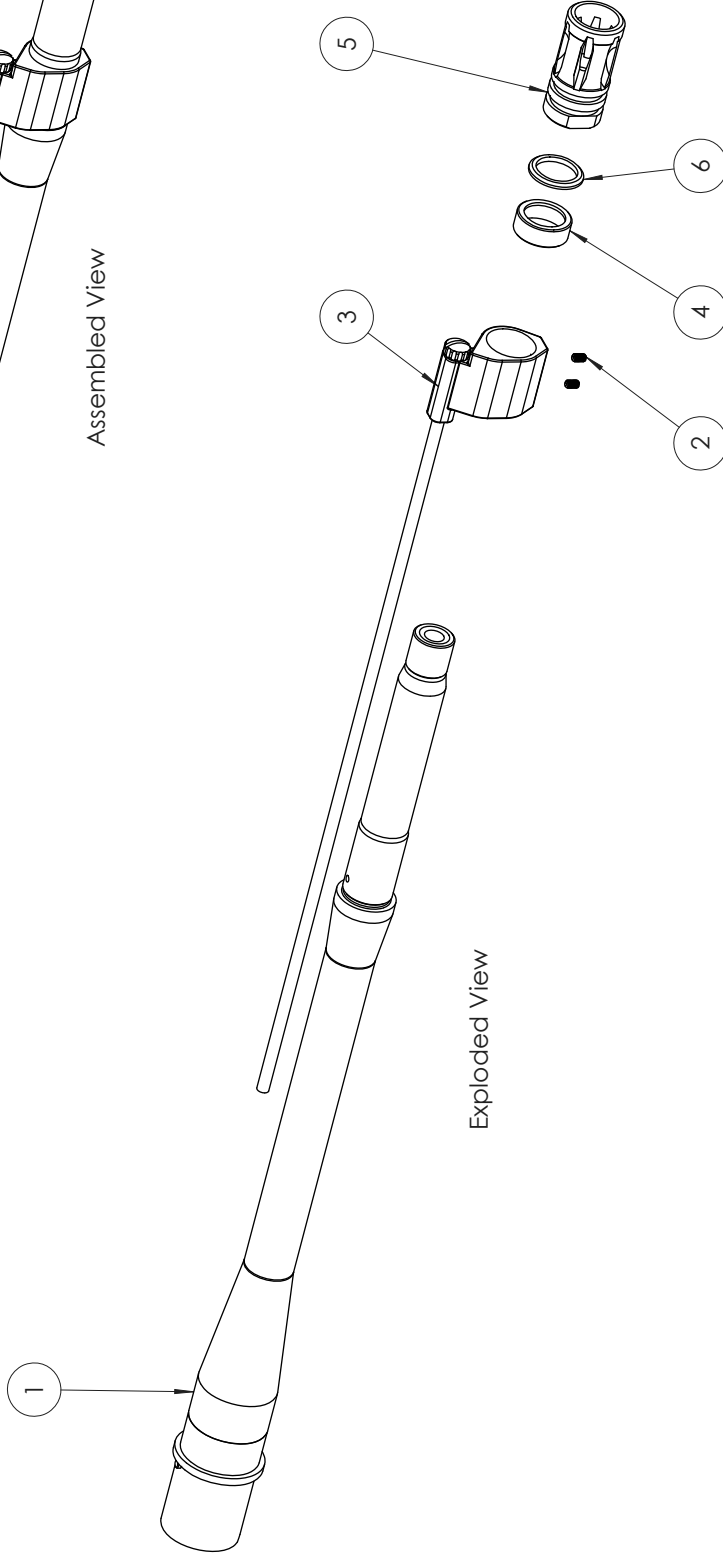
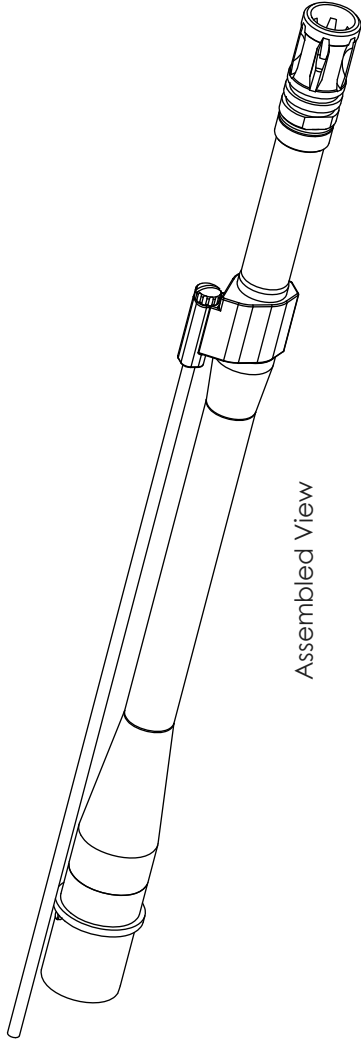

16 INCH INTERMEDIATE LENGTH BARREL ASSEMBLY

ITEM NO.	PART NUMBER	DESCRIPTION	QTY.
1	WT25-02-812	WT25 308 16" INTERMEDIATE LENGTH BARREL ASSEMBLY	1
2	WT25-00-0019	10/32 X 3/16 SET SCREW	2
3	WT25-00-8003	ADJUSTABLE GAS BLOCK INTERMEDIATE LENGTH	1
4	WT25-02-015	TAPER SPACER 308	1
5	WT25-00-1020	FLASH HIDER 5/8-24 THREAD	1
6	WT25-00-1021	CRUSH WASHER 5/8-24	1

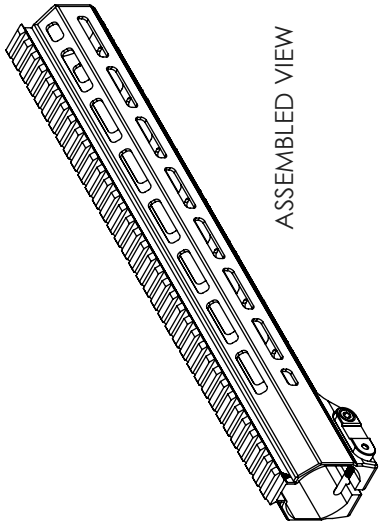

ASSEMBLED VIEW

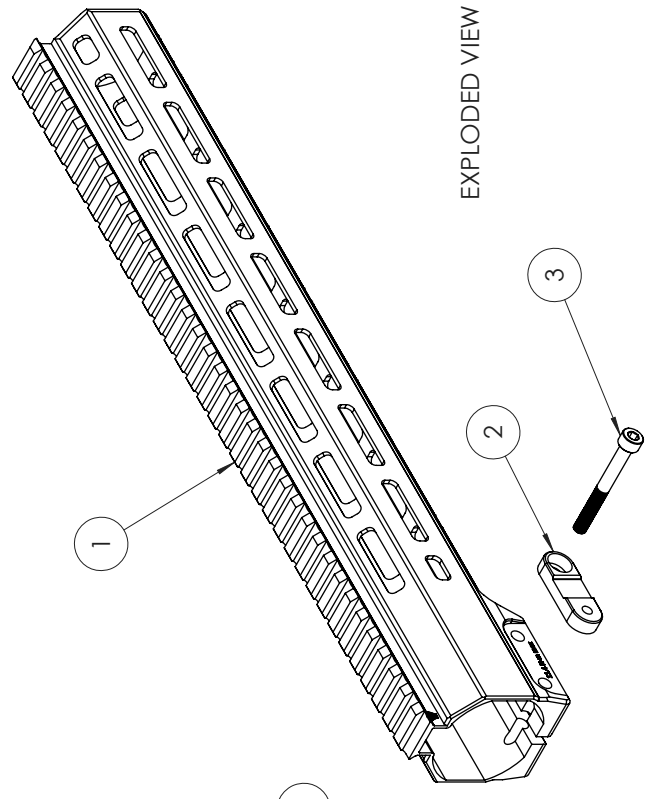

EXPLODED VIEW

ITEM NO.	PART NUMBER	DESCRIPTION	QTY.
1	WT25-02-010	HANDGUARD 14	1
2	WT25-02-016	XBOLT LOCK TAB M5	2
3	WT25-00-1016	SCREW M5x45 SHCS	2

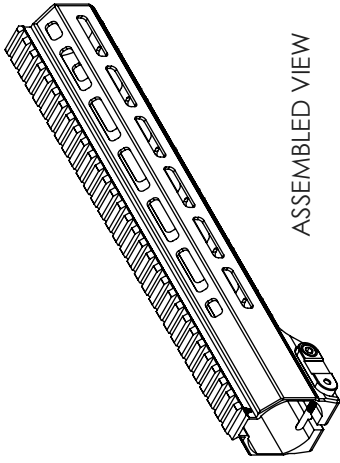

ASSEMBLED VIEW

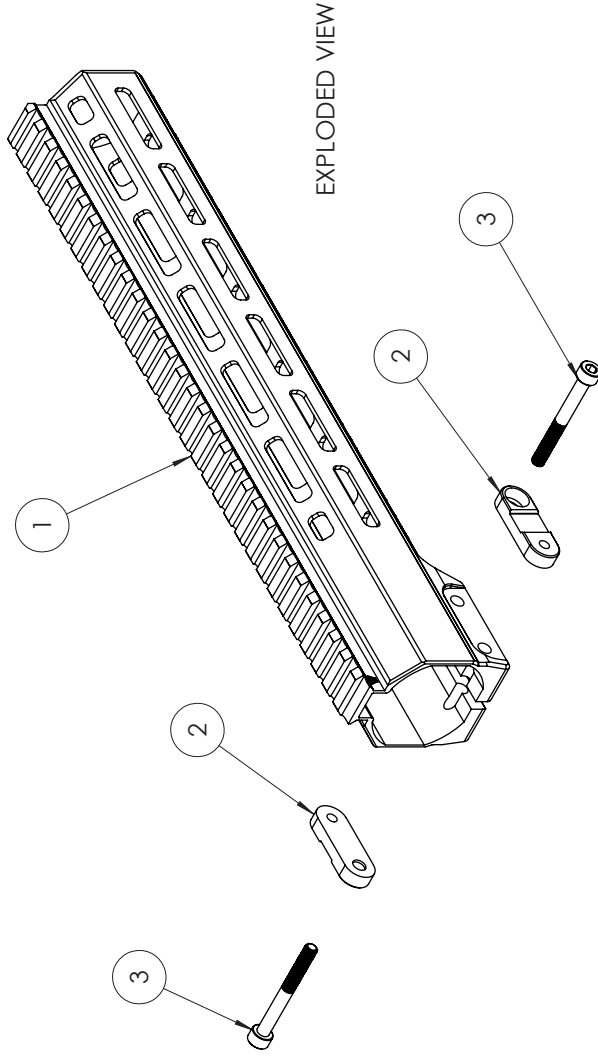

EXPLODED VIEW

ITEM NO.	PART NUMBER	DESCRIPTION	QTY.
1	WT25-02-011	HANDGUARD 12	1
2	WT25-02-016	XBOLT LOCK TAB M5	2
3	WT25-00-1016	SCREW M5x45 SHCS	2

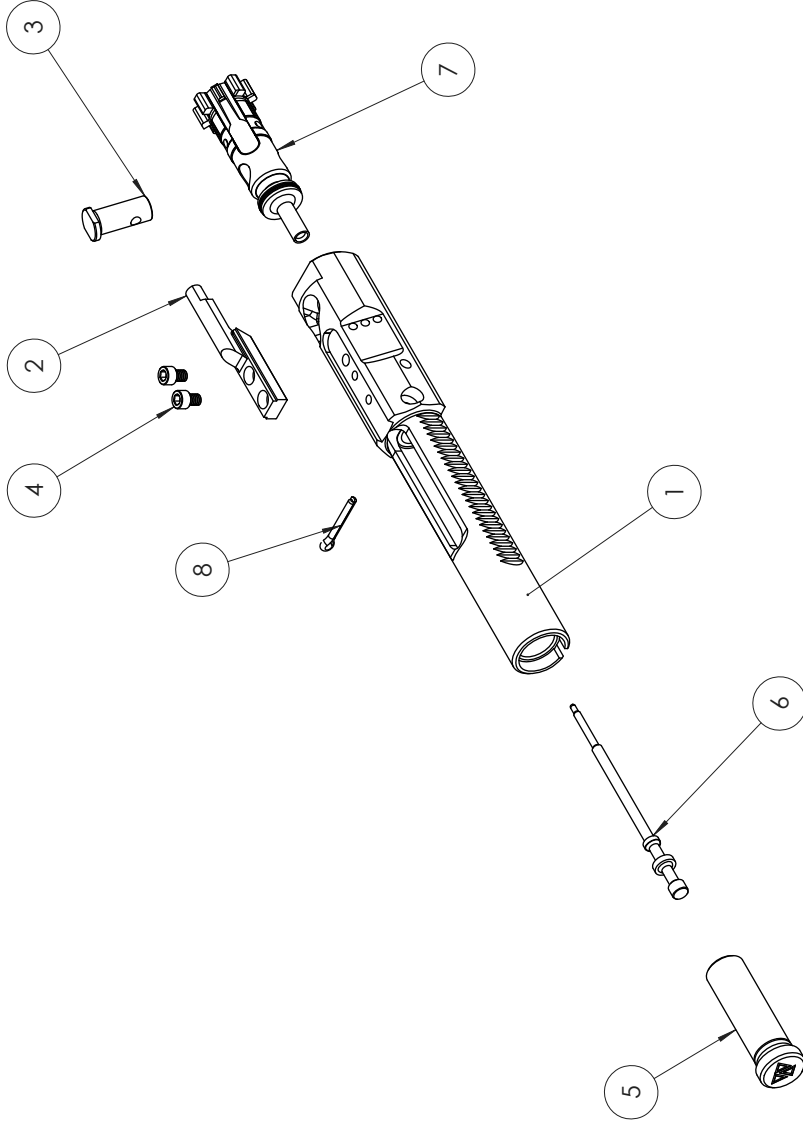

ITEM NO.	PART NUMBER	DESCRIPTION	QTY.
1	WT25-02-007	WT25 BOLT CARRIER	1
2	WT15-00-1024	AR15 GAS KEY	1
3	WT25-00-1006	AR 308 CAM PIN	1
4	WT15-00-1025	GAS KEY SCREW 8/32 X 1/8" SHCS	2
5	WT25-02-008	CARRIER WEIGHT ASSEMBLY	1
6	WT25-00-1007	AR10 FIRING PIN	1
7	WT25-02-811	WT25 308 BOLT ASSEMBLY	1
8	WT25-00-1008	COTTER PIN 7/64 DIA X 3/4 LENGTH	1

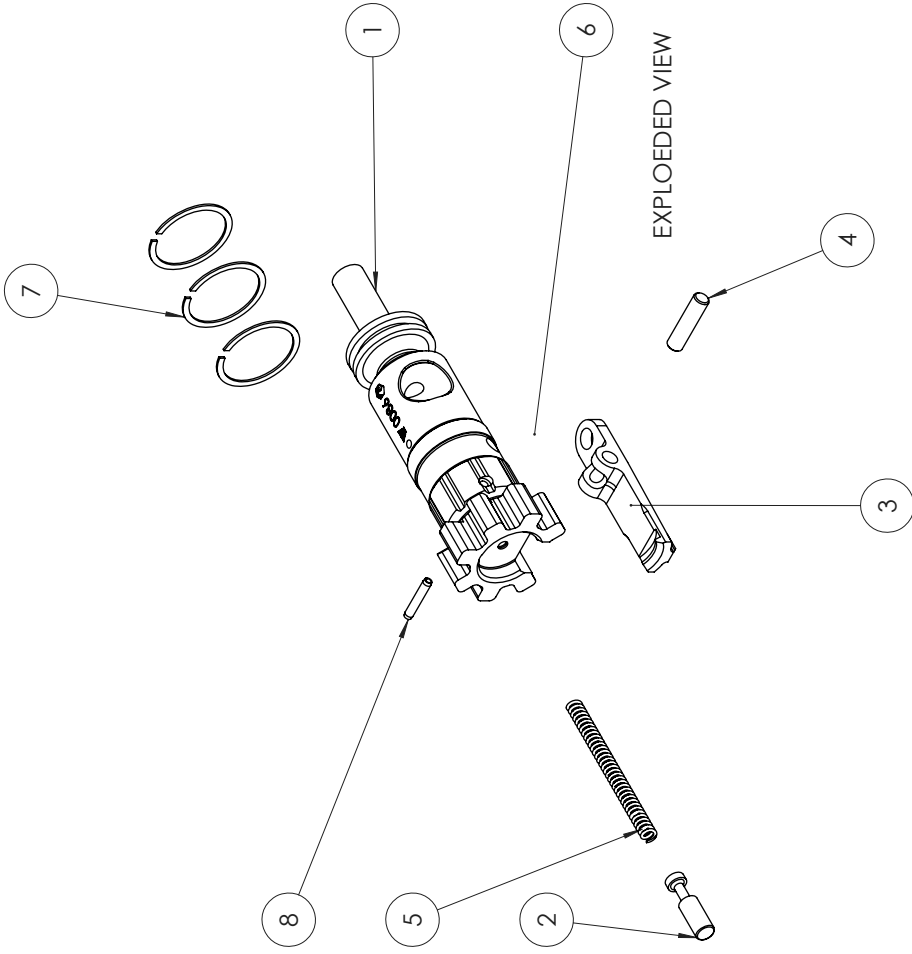
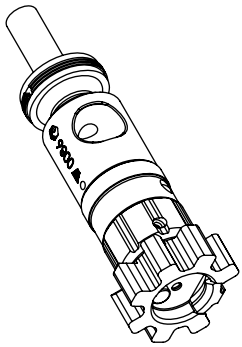

ITEM NO.	PART NUMBER	DESCRIPTION	QTY.
1	WT25-02-009	WEDGETAIL WT25 308 BOLT	1
2	WT25-00-1009	WT25 EJECTOR PLUNGER	1
3	WT25-00-1010	WT25 EXTRACTOR	1
4	WT25-00-1011	WT25 EXTRACTOR PIN	1
5	WT25-00-1012	WT25 EJECTOR PLUNGER SPRING	1
6	WT25-00-1013	AR308 EXTRACTOR SPRING	1
7	WT25-00-1014	AR308 GAS RING	3
8	WT25-00-1015	1/16" X 3/8" ROLL PIN	1